

# Freeform

PLASTICS

A Division of Bourgault Industries Ltd.

MT2000 HYDRAULIC SWATH ROLLER  
MODEL - MACDON M150/M200 SERIES & JOHN DEERE W150

ASSEMBLY INSTRUCTIONS & OPERATION  
EFFECTIVE S/N: 39632SR01 - DATE



View an installation on our Youtube Channel!

It is recommended to carefully follow the detailed steps of the assembly manual for the simplest and quickest assembly of the kit. Please check crate packing list against contents to be sure all parts have been received.

On all Free Form equipment, left and right are determined by standing behind the machine and looking forward.

All information, illustrations and specifications in this manual are based on the latest product information. Free Form updates products continually to improve quality. We reserve the right to make changes at any time.

## FREE FORM WARRANTY POLICY

Effective April 16, 2001

Free Form Plastic Products (referred to as Free Form), a Division of Bourgault Industries Ltd., warrants its **new**, unused, Agricultural Equipment to be free of defects in material and workmanship at time of the delivery to the first retail purchaser according to the Free Form Warranty Policy.

### 1) BASIC WARRANTY REPAIR PERIOD AND REMEDIES

- a) Free Form will repair or replace, at its option, without charge for parts or labour, **any defective part** of the equipment for a period of twelve (12) months from delivery to the first retail purchaser.
- b) Free Form will repair or replace, at its option, without charge for parts, any **Free Form manufactured part** that is found to be defective for the period of thirteen (13) months to twenty-four (24) months from delivery to the first retail purchaser.
- c) Free Form will repair or replace, at its option, for a charge of 50% of the parts, any **Free Form manufactured part** that is found to be defective for the period of twenty-five (25) months to thirty-six (36) months from delivery to the first retail purchaser.

**Note:** A **Free Form Manufactured Part** is any part which has been manufactured by Free Form. Parts purchased from an outside supplier are not considered to be manufactured by Free Form. Purchased parts would include bearings, bolts, etc...

- d) Any parts that are covered by an Extended Warranty published by Free Form, are an exception to the Basic Policy, and are to be warranted as per the details of the Extended Warranty document. The extended warranty policy may change from time to time without warning from Free Form.

### 2) EXTENDED WARRANTY

- a) **CULTIVATOR SHANKS** are warranted 100% for five years from date of manufacture against breakage. Breakage after the fifth year will

be covered at 50% warranty. Shanks are not warranted against bending, however, a bent shank policy is in place to provide Free Form customers with replacement shanks for 50% of list price.

### 3) EXCEPTIONS TO THIS WARRANTY

- a) In no event shall the owner be entitled to recover for incidental, special or consequential damages such as, but not limited to; loss of crop, loss of profit or revenue, other commercial losses, inconvenience or cost of rental of replacement equipment.
- b) **Repair, Maintenance, and Service items not related to defects:**
  - 1. Loss or damage during shipment (see: Free Form Wholegoods Shipping Policy)
  - 2. Failure resulting from lack of or improper maintenance.
  - 3. Damage caused by operator abuse, negligence, or improper operation.
  - 4. Non-defective items replaced due to customer demand unless authorized by Free Form.
  - 5. Nonreimbursable maintenance items including but not limited to oil, etc.
  - 6. Any and all costs for repairs or replacement of parts not shown to be defective.
  - 7. Damage due to accidents.
- c) **Cultivator Sweeps, Reversible Chisels, and Ground Engaging Tools** are **not** covered under this warranty policy, but by the warranty policy of their manufacturer.
- d) **Rubber Tires** are warranted directly by the tire manufacturer's agents only, and **not** by Free Form.
- e) **Replacement Parts** will be warranted for twelve months from the repair date, providing the bill of sale is attached to the warranty claim.
- f) The terms of this warranty are subject to Provincial and State Legislation. Free Form reserves the right to make changes in accordance with these Acts at any time without notification

**FREE FORM WARRANTY POLICY (CONT'D)**

or obligation. The stated warranty contained in the Free Form Warranty Policy applies in all situations, unless the law provides a greater warranty in the jurisdiction of the retail customer.

- g) Free Form reserves the right to continually improve its equipment, and reserves the right to change products or specifications at any time without notice or obligation.

**4) OWNER'S OBLIGATION**

It is the **responsibility of the owner, at the owner's expense, to transport the equipment to the service shop of an authorized Free Form Dealer (place of purchase) or alternately to reimburse the dealer for any travel or transportation expense** involved in fulfilling this warranty.

It is the **responsibility of the owner to read, understand and practice the maintenance, safety, and operational guidelines set out in the operator's manual** furnished with the equipment.

It is the owner's responsibility to ensure that the Warranty Registration, which must be signed by the owner, is completed and returned to Free Form by the dealer. The completed and signed Warranty Registration is required to register a new unit for warranty.

TABLE OF CONTENTS

FREE FORM WARRANTY POLICY.....2

1 SAFETY .....5

    1.1 GENERAL SAFETY .....6

    1.2 OPERATING SAFETY .....6

    1.3 MAINTENANCE SAFETY.....6

    1.4 TRANSPORT SAFETY.....6

2 HYDRAULIC FITTINGS ASSEMBY.....7

    2.1 HYDRAULIC FITTINGS ASSEMBY.....7

    2.2 VALVE BLOCK “AUX LIFT” INSTALL .....9

    2.3 AUX LIFT ELECTRICAL .....10

    2.4 RETURN CIRCUIT .....10

    2.5 SWITCH INSTALL .....11

    2.6 FINAL ASSEMBLY.....11

3 HYDRAULIC SWATH ROLLER USE AND OPERATION.....12

    3.1 ADJUSTING THE SWATH ROLLER .....12

    3.2 SETTING THE HYDRAULICS .....12

    3.3 SETTING THE DEPTH .....12

    3.4 TRANSPORT LOCKS .....13

4 HYDRAULIC PARTS .....14

    4.1 SWATHROLLER HYDRAULIC FITTINGS.....14

## 1 SAFETY

### SAFETY ALERT SYMBOL

This Safety Alert symbol means

**ATTENTION!**

**BECOME ALERT!**

**YOUR SAFETY IS  
INVOLVED!**



The Safety Alert symbol identifies important safety messages. When you see this symbol, be alert to the possibility of personal injury or death. Follow the instructions in the safety message.

Why is SAFETY important to you?

- Accidents Disable and Kill**
  - Accidents Cost**
  - Accidents Can Be Avoided**
- 3 Big Reasons**

#### SIGNAL WORDS:

Note the use of the signal words **DANGER**, **WARNING**, and **CAUTION** with the safety messages. The appropriate signal word for each message has been selected using the following guidelines:

#### **DANGER -**

Indicates an imminently hazardous situation that, if not avoided, will result in death or serious injury. This signal word is to be limited to the most extreme situations, typically for machine components that, for functional purposes, cannot be guarded.

#### **WARNING -**

Indicates a potentially hazardous situation that, if not avoided, could result in death or serious injury, and includes hazards that are exposed when guards are removed. It may also be used to alert against unsafe practices.

#### **CAUTION -**

Indicates a potentially hazardous situation that, if not avoided, may result in minor or moderate injury. It may also be used to alert against unsafe practices.

## 1 SAFETY (CONT'D)

**YOU** are responsible for the **SAFE** operation and maintenance of your Free Form equipment. **YOU** must ensure that you and anyone else who is going to operate, maintain or work around the equipment be familiar with the operating and maintenance procedures and related **SAFETY** information contained in this manual. This manual will take you step-by-step through your working day and alerts you to all good safety practices that should be adhered to while operating the unit.

Remember, **YOU** are the key to safety. Good safety practices not only protect you but also the people around you. Make these practices a working part of your safety program. Be certain that **EVERYONE** operating this equipment is familiar with the recommended operating and maintenance procedures and follows all the safety precautions. Most accidents can be prevented. Do not risk injury or death by ignoring good safety practices.

- The most important safety device on this equipment is a **SAFE** operator. It is the operator's responsibility to read and understand **ALL** Safety and Operating instructions in the manual and to follow these. All accidents can be avoided.
- Do not modify the equipment in any way. Unauthorized modification may impair the function and/or safety and could affect the life of the equipment.
- **Think SAFETY! Work SAFELY!**

### 1.1 GENERAL SAFETY

1. Read and understand the Operator's Manual
2. Have a first-aid kit available for use should the need arise and know how to use it.
3. Wear appropriate protective gear. This list may include but is not limited to:
  - A hard hat
  - Protective shoes with slip resistant soles
  - Protective goggles
  - Heavy gloves
  - Hearing protection

### 1.2 OPERATING SAFETY

1. Read and understand the Operator's Manual and all safety signs before using.
2. Attach securely to towing unit using a pin with a retainer.
3. Do not exceed a safe travel speed.
4. Use hazard flasher on towing unit when transporting.
5. Review safety instructions annually.

### 1.3 MAINTENANCE SAFETY

1. Follow good shop practices:
  - Keep service area clean and dry.
  - Be sure electrical outlets and tools are properly grounded.
  - Use adequate light for the job at hand.
2. Use only tools, jacks and hoists of sufficient capacity for the job.

### 1.4 TRANSPORT SAFETY

1. Read and understand **ALL** the information in the Operator's Manual regarding procedures and **SAFETY** when operating the swath roller in the field and/or on the road.
2. Always travel at a safe speed. Use caution when making corners or meeting traffic.
3. Make sure the reflectors required by the local highway and transport authorities are in place, are clean and can be seen clearly by all overtaking and oncoming traffic.

**Note:** The slow moving vehicle sign and flashing lights on the swather must be visible from behind when the MT2000 is secured in the transport position.

4. Be sure that the TB2000 is hitched positively to the towing vehicle and a retainer is used through the drawbar pin. Be sure that the MT2000 is secured properly with **both** transport locks and the pins are secured.
5. Keep to the right and yield the right-of-way to allow faster traffic to pass. Drive on the road shoulder, if permitted by law.
6. Do not exceed 20 m.p.h. (32 km/h). Reduce speed on rough roads and surfaces.

## 2 HYDRAULIC FITTINGS ASSEMBLY

### 2.1 HYDRAULIC FITTINGS ASSEMBLY

Refer to *Figures 2.1 & 2.2* for this step.

1. The LEFT hydraulic ram requires the following assemblies to be installed on the cap and rod ends. (#1) 2293 - 180" Hydraulic Hose 6FJX-6FJX90, (#2)-6MJ-6MP fitting (#3)-6FPT fitting, (#4)-6MP-6MP fitting, (#5)- Quick Coupler Male x 6FP, (#6)-Quick Coupler Female x 6FP, (#7) 2292 - 118" Hydraulic Hose 6FJX45-6FJX90, (#8) 2294 - 150" Hydraulic Hose 6FJX-6FJX90, (#9) 2291 - 130" Hydraulic Hose 6FJX-6FJX90

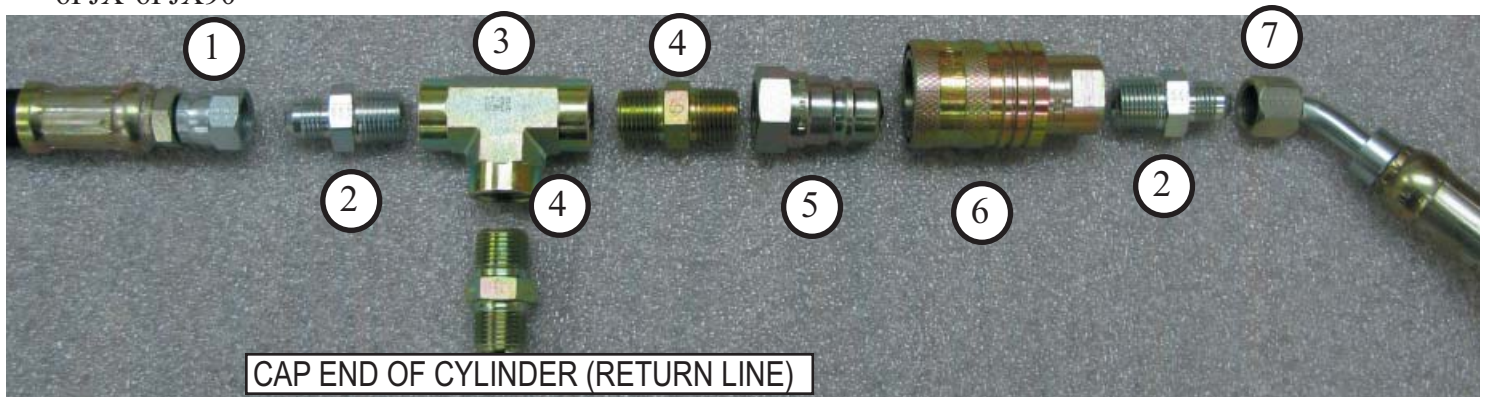

Figure 2.1 -Cap End Assembly of LEFT Cylinder

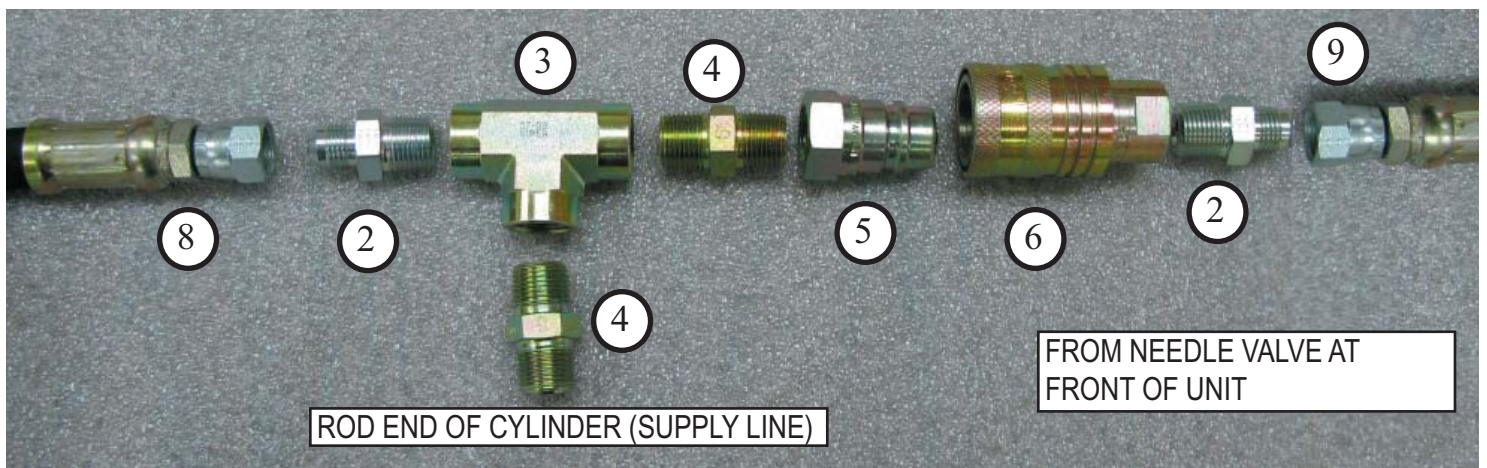

Figure 2.2 -Rod End Assembly of LEFT Cylinder

2. On the RIGHT cylinder, thread a (#2) 6MJ-6MP fitting into each end of the cylinder. Attach the 180" and 150" hydraulic lines to their corresponding end as per the assemblies of the LEFT cylinder.

**NOTE: USE PIPE DOPE ONLY ON FITTINGS WITH A PIPE THREAD.**

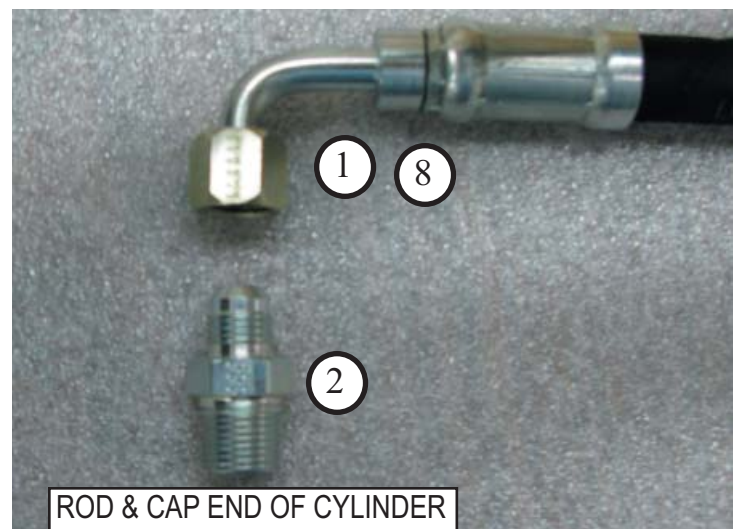
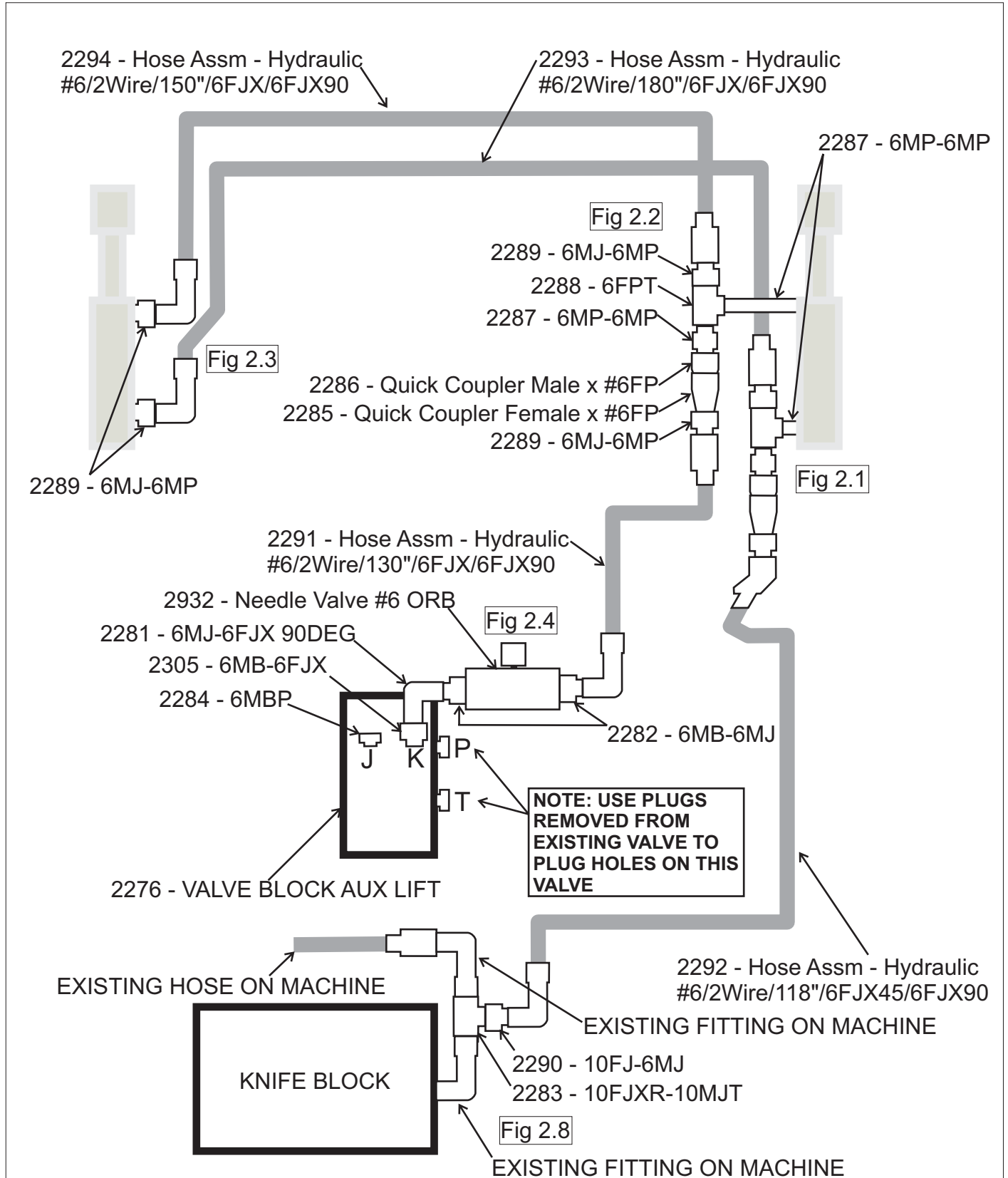

Figure 2.3 - Fitting Assembly of RIGHT Cylinder

# MACDON M150-M200 FFP Swathroller Hydraulic Diagram

## 2483 - FFP Swath Roller MT2000H - M150-M200 Macdon PKG





## 2.2 VALVE BLOCK “AUX LIFT” INSTALL

Refer to *Figures 2.4 & 2.5* for this step.

1. Remove the four (4) existing bolts from the right side of the LIFT VALVE block located under the driver’s side steps.
2. If the swather unit is equipped WITH the Reel Fore/Aft block then you need to use the  $\frac{3}{8}$ ” x 5- $\frac{1}{2}$ ” bolts (#18) to secure the Aux lift block. See *figure 2.5*. If the unit is NOT equipped with the Reel Fore/Aft control then you will only need to use the  $\frac{3}{8}$ ” x 3” bolts.

Note: The plugs removed from the side of the LIFT VALVE block are to be reinstalled on the AUX LIFT VALVE block.

3. Assemble the needle assembly as per *figure 2.4*. The parts are as follows; (#11)-6MBP (#12)-6MB-6FJX, (#13)-6MJ-6FJX90, (#14)-6MB-6MJ, (#15)-6ORB needle valve (Photo may not match the valve supplied), (#9) 2291 - 130” Hydraulic Hose 6FJX-6FJX90.

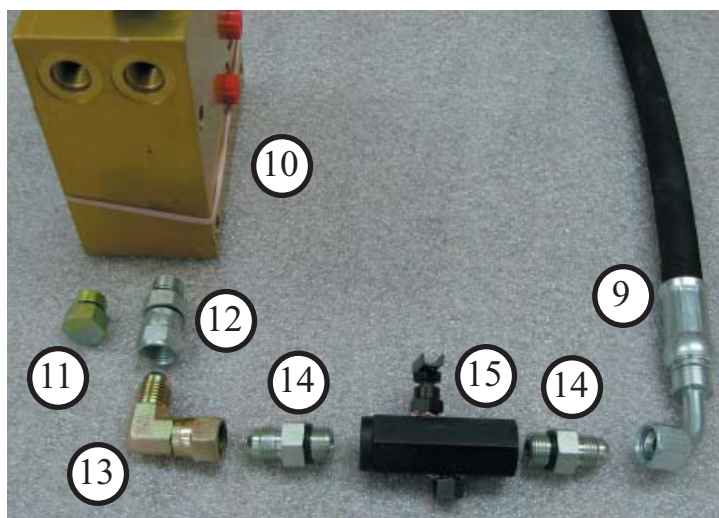

Figure 2.4 - "Aux" Lift Block Plumbing Parts



Figure 2.5 - Supply plumbing Assembly needle valve

## 2.3 AUX LIFT ELECTRICAL

Refer to *Figure 2.6* for this step.

1. The electrical connections required already exist in the harness. Use plug P72/P73 for the aux lift block electrical connection.

**Note:** In order activate the swath roller lift circuit (which is run from the Double Windrow Attachment circuit) it is necessary to ensure that the DWA circuit is activated. This is done by selecting the DWA circuit from within the Cab Display Module (CDM)- Tractor set up menu.

\*\*For details on this please see the swather operator's manual.

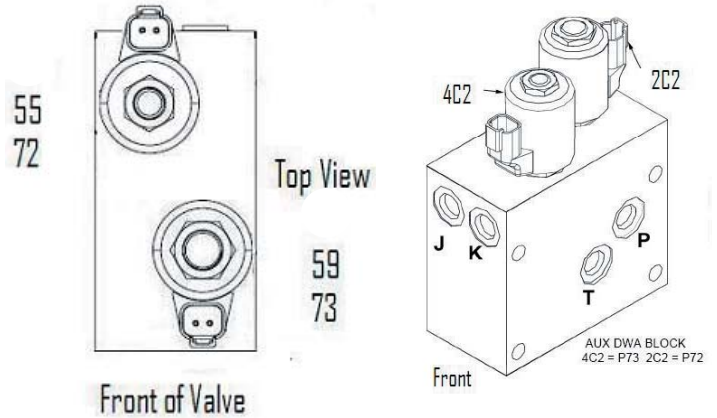

Figure 2.6 - Harness Connections

## 2.4 RETURN CIRCUIT

Refer to *Figures 2.7 & 2.8* for this step.

1. The return line connects to preexisting hydraulic lines with the use of (#19) 10FJXR-10MJT fitting and a (#20) 10FJ-6MJ fitting.
2. Locate the (#21) KNIFE block on the swather.
3. Separate the existing hydraulics between (#22) and (#23) in *figure 2.8*
4. Install the “T” (#19) and the reducer (#20).
5. Connect the other end of the return line 2292 - 118” Hydraulic Hose 6FJX45/6FJX90 from the hydraulic ram (#7) to the reducer (#20).

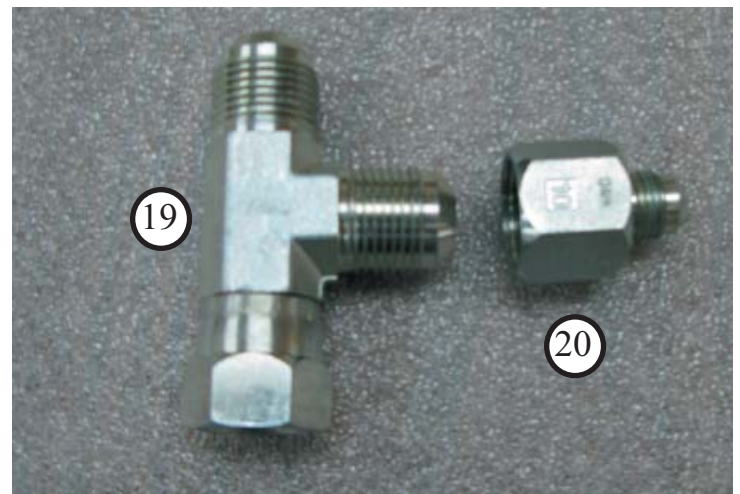

Figure 2.7 - Return Circuit Parts

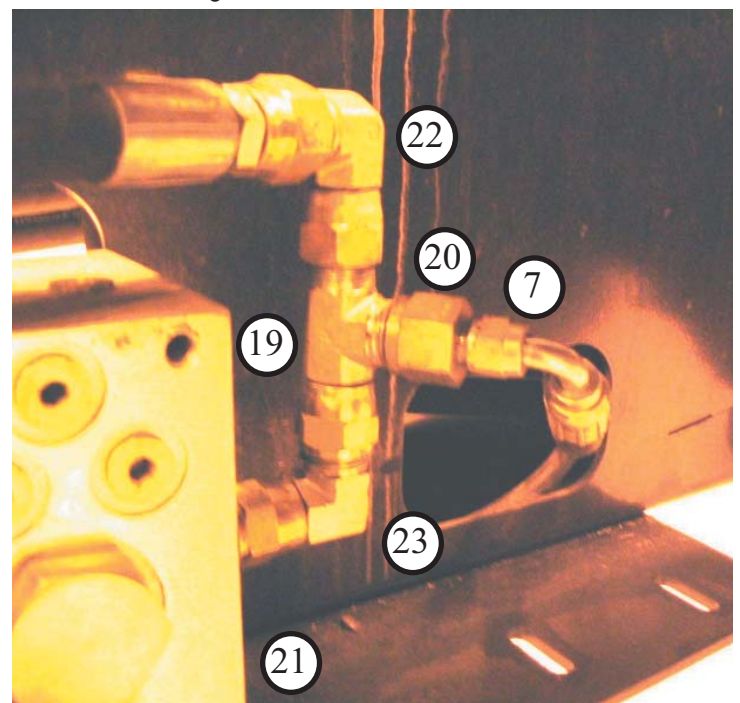

Figure 2.8 - Return Circuit Assembly

## 2.5 SWITCH INSTALL

Refer to *Figures 2.10 & 2.9* for this step.

1. The wiring for the switch already exists in the factory harness.
2. There is a switch knockout in the console plate behind the decal.
3. Using a sharp blade, cut out the black decal surrounding the switch hole.
4. The switch blank is held in place by small metal tangs. Remove the blank by cutting the tangs with a small hacksaw.
5. Remove the five (5) retaining screws that hold the console plate to the console.



Figure 2.9-Switch Installation Bottom View



Figure 2.10 -Switch Installation Top View

6. Lift up on the console plate and locate the harness connector plug (#94 in M150/200)
7. Push switch down into hole from the top side of the console and plug into harness connector (#94).
8. Switch orientation will have to be determined once the roller is fully mounted.
9. Pressing down at the REAR of the switch should LIFT the roller.
10. Pressing down at the FRONT of the switch should LOWER the roller.

## 2.6 FINAL ASSEMBLY

Adjust the swath roller assembly up and down. Check for binding, interference, or loose bolts. Check that the transport arms can lock into place.

Apply the decals as per the parts pages at the end of this booklet.

**Note:** The SMV (Slow Moving Vehicle) sign and lights must be visible from the rear. Move the SMV sign and/or lights if required to ensure their visibility.

## 3 HYDRAULIC SWATH ROLLER USE AND OPERATION

### 3.1 ADJUSTING THE SWATH ROLLER

Refer to *Figure 3.1* for this step.

1. To adjust the width of your swath roller, loosen the two (2) pins on each end of the swath roller (#24).
2. Slide the ends in or out to the desired width. The width of the roller is marked on the main drum. It is recommended to adjust the roller width so as to place the the average width of crop half way up the tapered end.
3. Tighten the pins once the width is set.

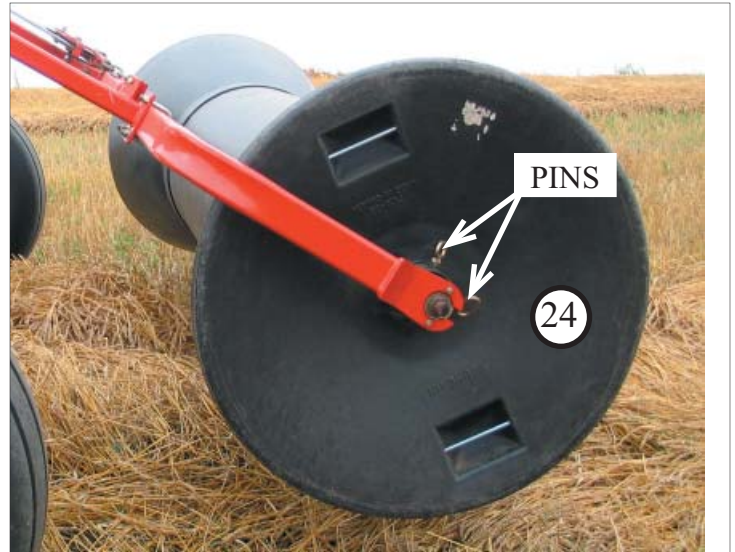

Figure 3.1 - Roller Adjustment

### 3.2 SETTING THE HYDRAULICS

Refer to *Figure 3.2* for this step.

1. The roller is adjustable up and down using the switch in the cab.
2. The needle valve at the front hydraulic block is used to control the rate of movement.
3. Turning the knob **CLOCKWISE** will **SLOW** the roller's rate of movement while turning the knob **COUNTER CLOCKWISE** will **INCREASE** the roller's rate of movement.
4. After cycling the roller up and down a few times, check the swather's hydraulic fluid level and top up if required.

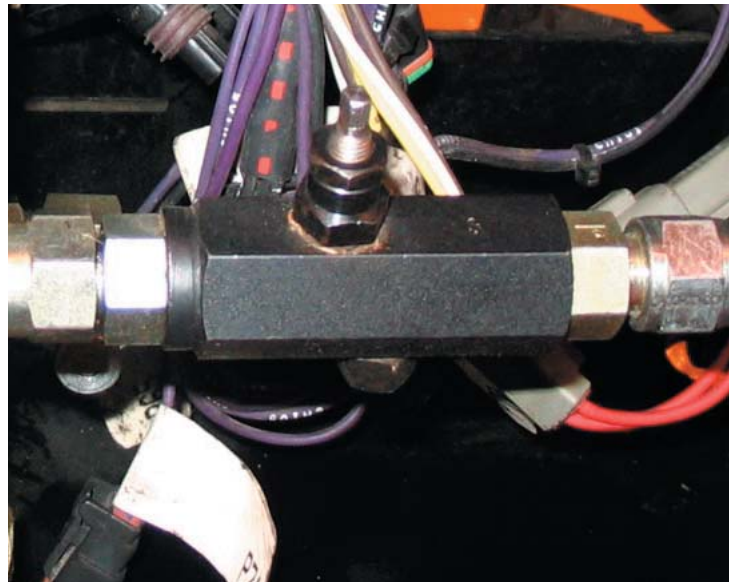

Figure 3.2 - Needle Valve  
(Photo may not match the valve supplied)

### 3.3 SETTING THE DEPTH

Refer to *Figure 3.3* for this step.

1. The roller assembly can be set to lower to a predetermined stop point using the bars next to the hydraulic rams.
2. Using a combination of the holes on the main bar and the holes of the sliding collar (#20), you can set the roller's minimum height.
3. Secure the collar (#20) with the supplied locking pin (#13).

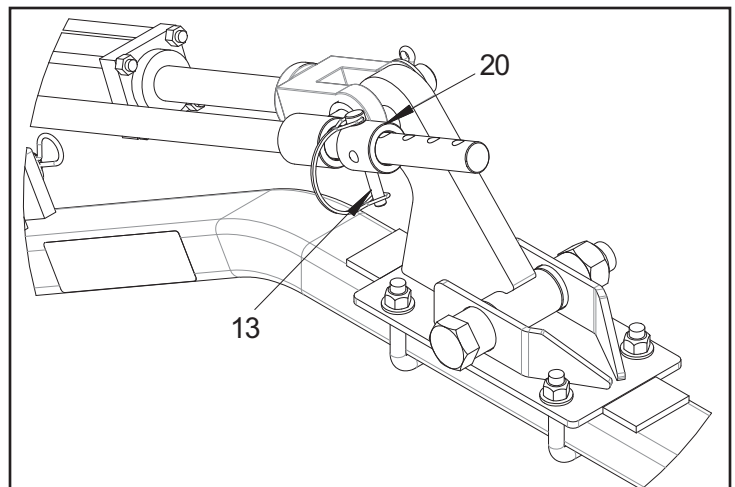

Figure 3.3 - Depth Adjustment

# Free *Form* PLASTICS

## 3.4 TRANSPORT LOCKS

Refer to *Figure 3.4* for this step.

1. When transporting the swather or while driving the unit on roadways, use the roller assembly's transport locks. This will take the weight off of the hydraulic components and increase service life.
2. Remove the pin (#16) from the ram/cylinder mounting tab (#24), location "A".
3. Raise the swath roller until the hole in transport lock lever (#25) lines up with the holes on the ram/cylinder mounting tab (#24).
4. Insert the pin (#16) through all holes and secure with a cotter pin (#12).
5. Lower the roller to relieve pressure on the hydraulics.

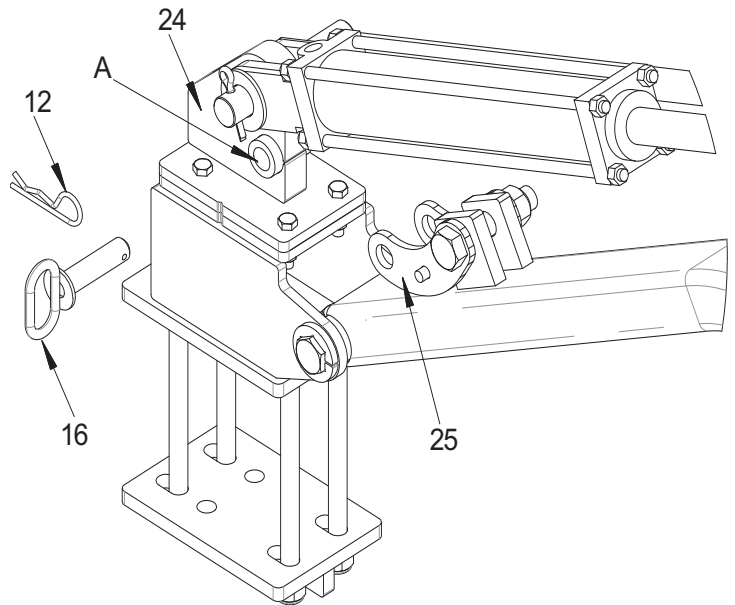

Figure 3.4 - Transport Lock

NOTE: If you are having trouble getting the pins in the transport lock you can rotate(thread) the clevis of the cylinder in order to adjust to fit.

## 4.1 SWATHROLLER HYDRAULIC ASSEMBLY

PART #	DESCRIPTION	QTY.
2276	VALVE BLOCK AUX LIFT .....	1
2278	SWITCH ELECTRICAL ROCKER .....	1
2281	6MJ-6FJX90 .....	1
2282	6MB-6MJ .....	2
2283	10FJXR-10MJT .....	1
2284	6MBP.....	1
2285	QUICK COUPLER FEMALE 6FP.....	2
2286	QUICK COUPLER MALE 6FP.....	2
2287	6MP-6MP .....	4
2288	6FPT .....	2
2289	6MJ-6MP .....	6
2290	10FJ-6MJ .....	1
2291	HOSE/#6/2WIRE/130/6FJX45/6FJX90.....	1
2292	HOSE/#6/2WIRE/118/6FJX45/6FJX90 .....	1
2293	HOSE/#6/2WIRE/180/6FJX45/6FJX90.....	1
2294	HOSE/#6/2WIRE/150/6FJX45/6FJX90.....	1
2305	6MB-6FJX.....	1
2932	VALVE HYDRAULIC NEEDLE 6 ORB .....	1





Visit us online at our website.