



Freeform  
PRODUCT CATALOGUE

# INDEX



A wide selection of high quality innovative storage tank solutions and agricultural products.

<b>VERTICAL FLAT AND CONE BOTTOM TANK</b>	<b>4</b>
<b>    GEN2 TANK</b>	<b>6</b>
<b>    LOW PROFILE TANK</b>	<b>8</b>
<b>STATIONARY CONE BOTTOM TANK STAND</b>	<b>9</b>
<b>STATIONARY CONE BOTTOM TANK CRADLE</b>	<b>9</b>
<b>TRANSPORTABLE CONE BOTTOM CRADLE</b>	<b>10</b>
<b>TRANSPORTABLE CONE BOTTOM STAND</b>	<b>10</b>
<b>    TURTLE TANK</b>	<b>11</b>
<b>    RURAL WATER TANK</b>	<b>12</b>
<b>MIXSYS FOR DRY CONCENTRATE IN LIQUID BLENDING</b>	<b>13</b>
<b>    VARIOUS TANKS</b>	<b>13</b>
<b>    ELLIPTICAL SPRAYER TANK</b>	<b>14</b>
<b>    AUXILIARY SPRAYER TANK</b>	<b>15</b>
<b>LIQUID FERTILIZER SCALE STATION</b>	<b>15</b>
<b>LIQUID FERTILIZER CART</b>	<b>16</b>
<b>PORTABLE LIQUID STORAGE</b>	<b>18</b>
<b>    SWATH ROLLER</b>	<b>20</b>
<b>    3-POINT HITCH CULTIVATOR</b>	<b>22</b>
<b>    DOWNSPOUTS &amp; AUGER HOPPERS</b>	<b>23</b>



## ROTO-SHEAR

A high quality vertical crop cutter adaptable to all swather and combine header boards, cutting through tangled and lodged crops with speed and efficiency.

24

## CHEMBINE

The Chembine Chemical Mixer that saves time and effort by mixing and blending chemicals for your sprayer. Learn more about our Hot-Tank for the quickest fills available.

26

## easyFlow

Closed chemical transfer systems.

30

## FENDERCO

Polyethylene plastic fenders for semi-trucks, trailers, motor graders and backhoes.

32



## TANKGUARD

A revolutionary GPS-based wireless tank location and level reporting system. Reports level, location, temperature, usage history and demand forecast information 24/7.

38



## POLAR GRIP

TRUCK WEIGHT SYSTEM

Truck Bed weight system for increase traction and braking without taking up truck bed space.

42



## POLYTOON™

Commercial or residential floating dock systems.

44

# VERTICAL TANK

## VERTICAL FLAT BOTTOM

- 1 Heavy-duty, reinforced ribbed dome prevents sagging.  
All tanks have greater than UV20 protection to prevent deterioration from sunlight.
- 2 16" Vented Hinged Lid.
- 3 Gallonage Indicator - All tanks have been calibrated, and indicate fluid levels.
- 4 Banjo heavy-duty bulkhead fitting and interior siphon tube for more complete drainage. *(An optional 2" Banjo heavy-duty bulkhead fitting is available in lieu of the standard 3" on all large size tanks.)*

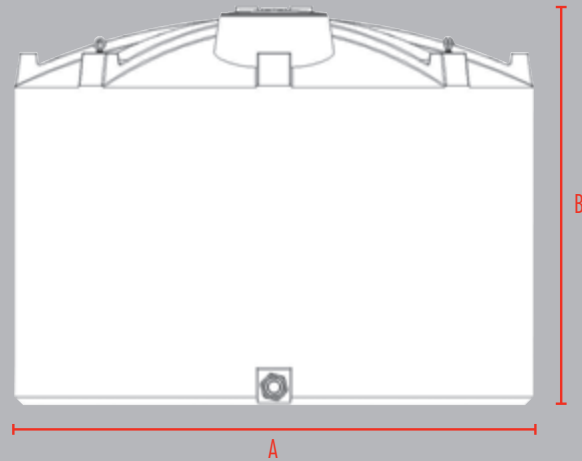

### VERTICAL FLAT BOTTOM TANK SPECIFICATIONS

CAPACITY		SPECIFICATIONS					PART NUMBER			
IMP. GAL.	U.S. GAL.	DIM. A	DIM. B	LID SIZE	STANDARD FITTING	SD WHITE	HD WHITE	SD BLACK	HD BLACK	
5000	6000	120"	139"	16"	3" HD	2298	2299	2415	2416	
3700	4440	104"	134"	16"	3" HD	1332	1333	1334	1335	
2500	3000	102"	93"	16"	3" HD	1328	1329	1330	1331	
2000	2400	102"	78"	16"	3" HD	1324	1326	1325	1327	
1750	2100	92"	88"	16"	3" HD	1056	1054	1047	1053	
1500	1800	102"	60"	16"	3" HD	1425	1426	1427	1428	
1400	1680	88"	74"	16"	3" HD	1411	1412	1413	1414	
1250	1500	88"	68"	16"	3" HD	1407	1408	1409	1410	
590	708	48"	102"	12"	2" HD	26004-32	26004-34	26004-33	26004-35	
500	600	57"	60"	8"	2" HD	1373	1153	1429	1430	

**SD tanks** the Standard-Duty (SD) version is used for water and other liquids with densities up to 14 lb per gallon.

**HD tanks** the Heavy-Duty (HD) version is specifically designed for liquid fertilizers and other liquids with densities up to 20 lb per gallon.

Free Form's 1750 imperial gallon flat bottom tank is specifically designed to fit most truck boxes where larger capacities are needed but the truck box width is limited.

### VERTICAL 1750 IMP. GAL. FLAT BOTTOM

CAPACITY		SPECIFICATIONS						
IMP. GAL.	U.S. GAL.	DIM. A	DIM. B	DIM. C	DIM. D	LID SIZE	STANDARD FITTING	
1750	2100	80"	88"	92"	26"	16"	3" HD	

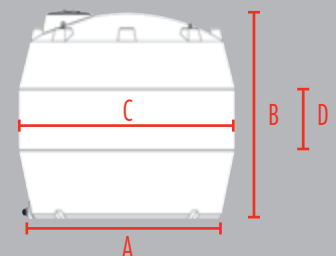



## VERTICAL CONE BOTTOM

Cone bottom tanks feature a 10 degree slope which means lower overall heights, complete product drainage, and a more stable load when transporting.

- ▶ All tanks, except low-profile, are available in translucent white, black, or GEN2. Low-profile tanks are available in translucent white, and GEN2. (*Black and GEN2 tanks eliminate algae formation.*)



- ▶ All tanks are manufactured from materials that meet FDA Regulations 21 CFR 177.1520, and may be used to contain materials for human consumption.
- ▶ Sight gauges available to allow product visibility in black and GEN2 tanks.

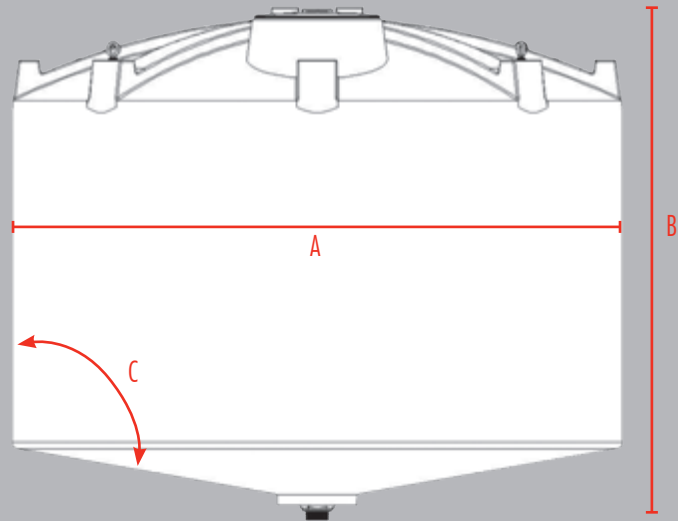

### VERTICAL CONE BOTTOM TANK SPECIFICATIONS

CAPACITY		SPECIFICATIONS						PART NUMBER			
IMP. GAL.	U.S. GAL.	DIM. A	DIM. B	DIM. C	LID SIZE	STANDARD FITTING	SD WHITE	HD WHITE	SD BLACK	HD BLACK	
3700	4440	104"	136"	10°	16"	3" HD	1341	1339	1431	1432	
2500	3000	102"	95"	10°	16"	3" HD	1342	1338	1433	1434	
2000	2400	102"	80"	10°	16"	3" HD	1343	1340	1435	1436	
1500	1800	102"	62"	10°	16"	3" HD	1400	1401	1402	1403	
1400	1680	88"	76"	10°	16"	3" HD	1419	1420	1421	1422	
1250	1500	88"	70"	10°	16"	3" HD	1415	1416	1417	26000-14	
22	26.4	22-1/2"	21-1/4"	10°	12"	3/4"	1148	N/A	N/A	N/A	
12	14.4	19"	16-1/2"	10°	12"	3/4"	2400-68	N/A	N/A	N/A	

# GEN2 TANK



Algae growth and contamination have always been problems with water transport tanks. Black tanks have typically been used to overcome this problem, but because of the heat absorption of black the inherent strength of the tank is compromised making it difficult to securely fasten the tank for transport. The design staff at Free Form Plastics have developed an innovative tank which eliminates algae growth without sacrificing the tank's structural integrity. On the outside it appears to be a standard white tank, but the inside is black to block UV rays.

- ▶ GEN2 tanks are available in the following sizes: 1150, 1250, 1350, 1400, 1500, 1750, 1950, 2000, 2500, 2650, 3250 imp. Gallon (1380, 1500, 1620, 1680, 1800, 2100, 2340, 2400, 3000, 3180, 3900 U.S. gallon)
- ▶ All GEN2 tanks have greater than UV20 protection to prevent deterioration from sunlight.
- ▶ Sight tube kits available to allow product visibility.
- ▶ Locations for sight tube kits are pre-installed. All GEN2 tanks are equipped with 4 load/unload hooks.
- ▶ GEN2 tanks are only available in the HD version which carries a 10 Year Warranty against defects in workmanship. All HD tanks are rated for liquids up to 20 lb per gallon for liquid fertilizers, etc.
- ▶ GEN2 is available in flat, cone or low profile versions.



GEN2 Patents: US 7,118,700 & CDN 2,431,215





## VERTICAL FLAT BOTTOM SPECIFICATIONS

CAPACITY		SPECIFICATIONS				PART NUMBER	
IMP. GAL.	U.S. GAL.	DIA.	HIGH	LID SIZE	STANDARD FITTING	TANK VERSION	GEN2
2500	3000	102"	93"	16"	3" HD	HD	1798
2000	2400	102"	78"	16"	3" HD	HD	1796
1750	2100	92"	88"	16"	3" HD	HD	1781
1500	1800	102"	60"	16"	3" HD	HD	1794
1400	1680	88"	74"	16"	3" HD	HD	1576
1250	1500	88"	68"	16"	3" HD	HD	1556



## VERTICAL CONE BOTTOM (10° SLOPE) SPECIFICATIONS

CAPACITY		SPECIFICATIONS				PART NUMBER	
IMP. GAL.	U.S. GAL.	DIA.	HIGH	LID SIZE	STANDARD FITTING	TANK VERSION	GEN2
2500	3000	102"	95"	16"	3" HD	HD	1792
2000	2400	102"	80"	16"	3" HD	HD	1790
1500	1800	102"	62"	16"	3" HD	HD	1788
1400	1680	88"	76"	16"	3" HD	HD	1612
1250	1500	88"	70"	16"	3" HD	HD	1702



## LOW PROFILE TANK SPECIFICATIONS

CAPACITY		SPECIFICATIONS				PART NUMBER	
IMP. GAL.	U.S. GAL.	WIDTH	HIGH	LENGTH	LID SIZE	TANK VERSION	GEN2
3250	3900	90"	74"	191"	21"	HD Modular	2725
2650	3180	92"	78"	144"	16"	HD 1 Piece	3012
1950	2340	92"	62"	145"	16"	HD 1 Piece	2304
1350	1620	78"	53"	144"	21"	HD 1 Piece	2139
1150	1380	88"	29"	144"	21"	HD 1 Piece	26000-54

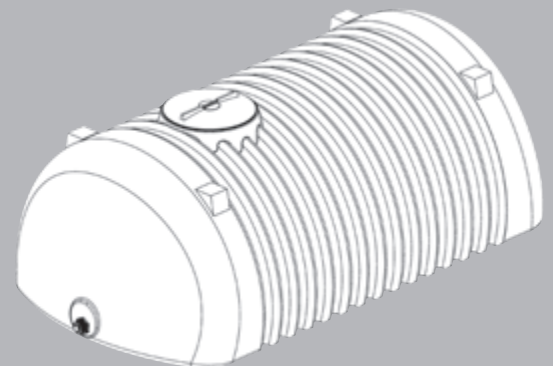

# LOW PROFILE TANK



CAPACITY		SPECIFICATIONS				PART NUMBER	
IMP. GAL.	U.S. GAL.	WIDTH	HIGH	LENGTH	LID SIZE	HD WHITE	GEN2
3250	3900	90"	74"	191"	21"	2726 Modular	2725 Modular
2650	3180	92"	78"	144"	16"	3013 1 Piece	3012 1 Piece
1950	2340	92"	62"	145"	16"	2194 1 Piece	2304 1 Piece
1350	1620	78"	53"	144"	21"	1888 1 Piece	2139 1 Piece
1150	1380	88"	29"	144"	21"	26000-53 1 Piece	26000-54 1 Piece

- ▶ 3" Banjo bulkhead fitting is standard and comes with an interior siphon tube for better drainage. Except where noted.
- ▶ Available in HD White, or GEN2 (white exterior, black interior) versions. Except where noted.
- ▶ The 1150 imp. gal. (1380 U.S. gal.), the 1350 imp. gal. (1620 U.S. gal.), the 1950 imp. gal. (2340 U.S. gal.), and the 2650 imp. gal. (3180 U.S. gal.) are a 1-piece design.
- ▶ Extreme ribbing allows for easy tie-down eliminating the need for additional metal support hoops.
- ▶ Optional metal tie down hoops and ladders are available.

- ▶ The 500 imp. gal. (600 U.S. gal.)
- ▶ Comes with a 2" HD Bulkhead.
- ▶ Available in white and black.

CAPACITY		SPECIFICATIONS				PART NUMBER	
IMP. GAL.	U.S. GAL.	WIDTH	HIGH	LENGTH	LID SIZE	WHITE	BLACK
500	600	50"	50.5"	80"	16"	26005-15 1 Piece	26005-25 1 Piece

## ADDITIONAL FEATURES OF THE LARGE MODULAR TANKS (3250 imp. gal. tank)

- ▶ Dual compartment tanks allow for use of different liquids in each tank section (*factory order*), or use as one large tank where liquid flows between both sections.
- ▶ Ideal for drop-deck trailers, grain truck boxes and other applications.

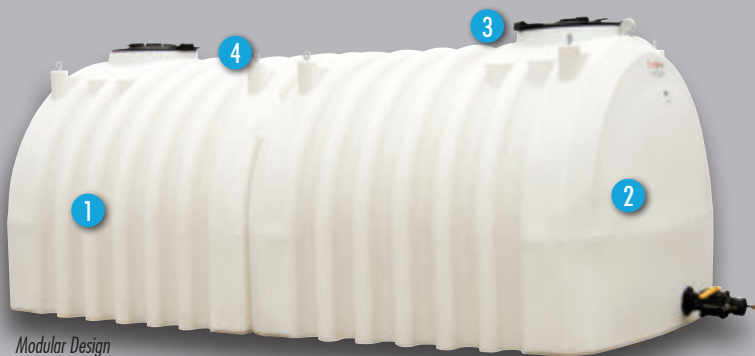

Modular Design

## LOW PROFILE TANK FEATURES

- 1 Extreme ribbing and heavy-duty design eliminate the need for steel support hoops. Large ribs act as baffles reducing the amount of sloshing.
- 2 Domed ends add strength and reduce sloshing.
- 3 Large hinged manhole for easy access if required.
- 4 Complete with unload/load hooks.



# STATIONARY CONE BOTTOM TANK STAND

- ▶ Completely welded seams make this unit ideal for liquid fertilizer applications.
- ▶ Stands available for 1250, 1400, 1500, 2000, 2500 and 3700 imp. gal. tank sizes (1500, 1680, 1800, 2400, 3000, 4440 U.S. gal.)
- ▶ Stand will accept all cone bottom tanks that have a 10° slope.
- ▶ Complete metal bottom on large stands offer full tank support.
- ▶ Tank secured to stand with custom nylon straps and ratchets which are included.
- ▶ Stand constructed from heavy-duty steel tubing, comes with powder coated paint.
- ▶ Custom built stands are available.

## SPECIFICATIONS

DIA.	HEIGHT	WEIGHT (LB)	PART NUMBERS
101"	19"	970	26004-11
88"	20-½"	450	26004-12
Optional 2" plumbing kit for 101"			1772
Optional 3" plumbing kit for 101"			1596
Optional 2" plumbing kit for 88"			1771
Optional 3" plumbing kit for 88"			1773



# STATIONARY CONE BOTTOM TANK CRADLE

- ▶ Suitable for fabricating stationary cone stands.
- ▶ Optimal 10° slope angle.
- ▶ Will fit most tanks with 10° cone.
- ▶ Supplied unpainted.
- ▶ Handles liquid fertilizer tanks up to 3700 imp. gal.
- ▶ Cradles available for 1250, 1400, 1500, 2000, 2500 and 3700 imp. gal. tank sizes (1500, 1680, 1800, 2400, 3000, 4440 U.S. gal.)
- ▶ Tanks can be secured to the cradle with optional nylon straps and ratchets.

## SPECIFICATIONS

DIA.	HEIGHT	WEIGHT (LB)	PART NUMBERS
101"	10"	480	1285
88"	9"	375	1368

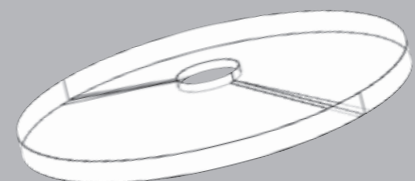

# TRANSPORTABLE CONE BOTTOM TANK STAND

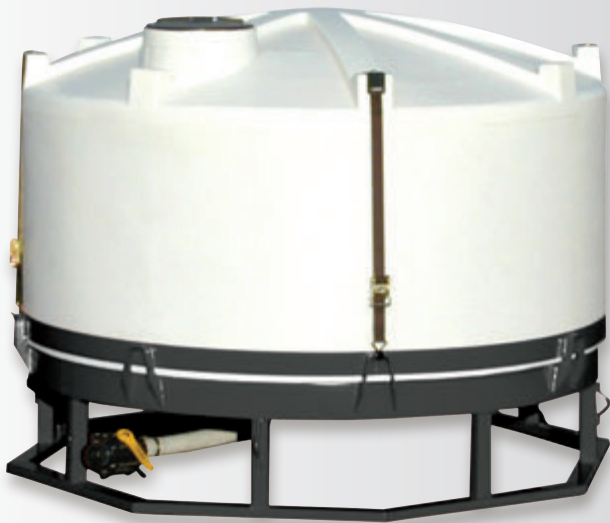

## TRANSPORTABLE CONE BOTTOM TANK STANDS

### SPECIFICATIONS

DIA.	HEIGHT	WEIGHT (LB)	PART NUMBERS
102"	24"	900	26004-09
88"	24"	600	26004-10
Optional 2" plumbing kit for 102"			1772
Optional 3" plumbing kit for 102"			1596
Optional 2" plumbing kit for 88"			1771
Optional 3" plumbing kit for 88"			1773

- ▶ Free Form Plastics cone bottom stands complete with cone bottom tanks are a safe and efficient way to transport liquid fertilizer, water, etc., to the field. The minimal 10° cone tank slope reduces the overall tank height resulting in increased safety. This also decreases the movement of liquid inside the tank compared to one large tank or a tanker unit.
- ▶ The complete drainage system means less maintenance. You don't have to worry about product being left in the tank. Optional 2" or 3" plumbing packages are available.
- ▶ Trailer stands are designed to be secured directly to the deck. In some cases they are welded directly to the deck. This is ideal if the trailer is solely dedicated for this particular job.
- ▶ Stands available for: 1250, 1400, 1500, 2000, and 2500 imp. gal. tank sizes (1500, 1680, 1800, 2400, 3000 U.S. gal.) cone bottom tanks.
- ▶ Tanks are available in white, black, or GEN2 styles.
- ▶ Stand constructed from heavy-duty steel tubing and comes with powder coated paint.
- ▶ Tank secured to stand with custom nylon straps and ratchets which are included.

# TRANSPORTABLE CONE BOTTOM TANK CRADLE

- ▶ Cradles available for 1250, 1400, 1500, 2000 and 2500 imp. gal. tank sizes (1500, 1680, 1800, 2400, 3000 U.S. gal.)
- ▶ Suitable for fabricating liquid carts or transportable tank stands.
- ▶ Designed with a 10° slope cone angle.
- ▶ Built-in tie lugs for strapping tank.
- ▶ Reinforced support ring for tank.
- ▶ Cradle assembly is not painted.
- ▶ Tanks can be secured to the cradle with optional nylon straps and ratchets.

### SPECIFICATIONS

DIA.	HEIGHT	WEIGHT (LB)	PART NUMBERS
102"	14-½"	600	1221
88"	14"	400	1691

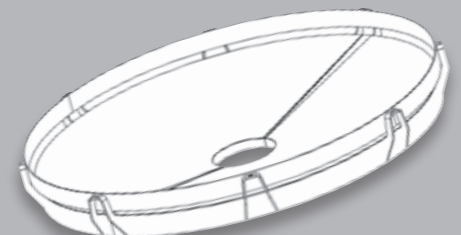



# TURTLE TANK



- ▶ Available in 2 sizes (175 and 250 imp. gal.). Both sizes come standard with molded in carry handles & tie down lugs, 8" vented lid, 2" Banjo heavy-duty bulkhead fitting, four (4) eye bolts and siphon tube for more complete drainage.
- ▶ Turtle tanks are available in translucent white or black. (Black eliminates algae formation.)
- ▶ All translucent and black tanks are manufactured from materials that meet FDA Regulations 21 CFR 177.1520, and may be used to contain materials for human consumption.
- ▶ Turtle tanks are typically used to contain liquids with densities up to 14 lb per gallon.
- ▶ All tanks have greater than UV20 protection to prevent deterioration from sunlight.
- ▶ Turtle tanks carry a 10 Year Warranty against defects in workmanship.

CAPACITY		SPECIFICATIONS					PART NUMBERS	
IMP. GAL.	U.S. GAL.	WIDTH A	HIGH B	LENGTH C	LID SIZE	STANDARD FITTING	WHITE	BLACK
175	210	57"	24"	47 <sup>-3/4</sup> "	8"	2"	1018	1357
250	300	57"	30"	47 <sup>-3/4</sup> "	8"	2"	1139	1356

*Turtle Tank Patent: CDN 2,361,945*

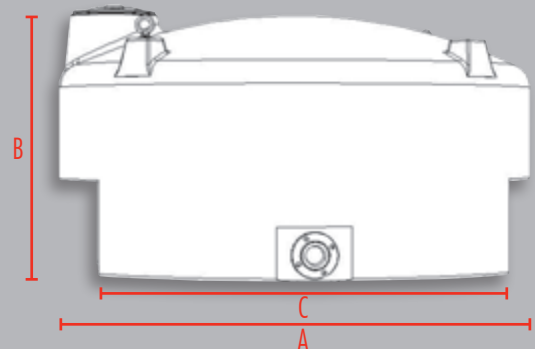

# RURAL WATER TANK

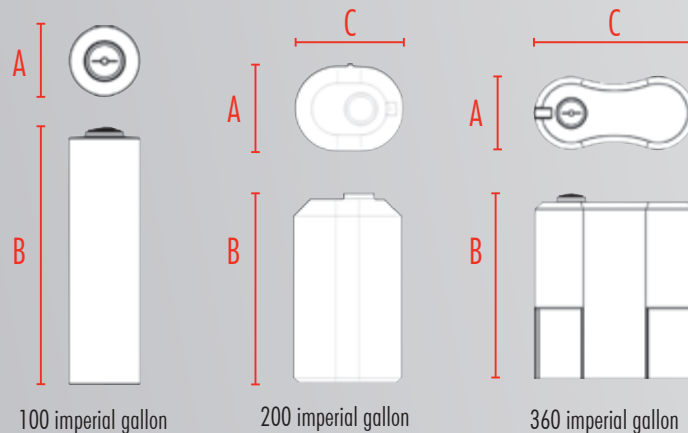

CAPACITY		SPECIFICATIONS					PART NUMBERS	
IMP. GAL.	U.S. GAL.	DIM. A	DIM. B	DIM. C	LID SIZE	STANDARD FITTING	WHITE	BLACK
360	432	30"	74"	65"	8"	1-1/4"	2168	26001-41
200 S	240	30"	66"	38"	8"	1-1/4"	1070	5256
200 T	240	28"	74"	34"	15"	1-1/4"	2950	26002-75
165	198	28"	60"	34"	15"	1-1/4"	2727	26000-95
100	120	22"	78"	N/A	8"	1-1/4"	1069	26001-39
14	16.8	N/A	21"	20-3/4"	6"	1-1/4"	CALL	1118

- ▶ Rural water tanks are available in translucent white, or black. (*Black eliminates algae formation.*)
- ▶ All translucent and black tanks are manufactured from materials that meet FDA Regulations 21 CFR 177.1520, and may be used to contain materials for human consumption.
- ▶ Rural water tanks have greater than UV20 protection to prevent deterioration from sunlight.
- ▶ Rural water tanks come standard with a vented lid and a Banjo heavy-duty bulkhead fitting.
- ▶ Optional float valve available.
- ▶ Sight gauges available to allow product visibility in black tanks.
- ▶ These are standard duty tanks which are typically used to contain liquids with densities up to 14 lb per gallon.
- ▶ Standard duty tanks carry a ten 10 Year Warranty against defects in workmanship.



# FOR DRY CONCENTRATE IN LIQUID BLENDING



The MIXSYS by Free Form Plastics is a cone bottom mixing tank that is designed to allow creation of custom blends whether liquid or solid (dry concentrate) (like Agrotain). Dumping large bulk bags/containers can be very difficult with a regular tank, but the MIXSYS is set up with a large 60" x 60" opening, ladder and plumbing to make it simple!

- ▶ HD 10° cone bottom tank allows for complete drainage.
- ▶ HD cone stand for easy and safe transporting.
- ▶ Cone bottom stands and cone bottom tanks available in 1500, 2000 and 2500 imp gal sizes.
- ▶ Easily secured to a trailer.
- ▶ Custom fabricated extra large tank top opening, with lid, to allow easy fills with bulk containers.
- ▶ Heavy-duty metal ladder.
- ▶ Agitation fittings installed for quick and easy mixing of your products.

**PUMPS:** There are 2 options of pumps to choose from to compliment your MIXSYS and create a very functional and compact system. One is a 6.5 hp Honda with a Wet Seal Banjo pump rated at 293 GPM or a 13 hp electric start Honda with Hypro pump displacing 440 gpm. Both pumps would come installed on a powder coated frame with plumbing to allow the unit to draw into the tank to fill, recirculate product in the tank and mix as well as unload the tank. The plumbing also allows it to be used to circulate product in storage tanks.

## VARIOUS TANKS



### 14 IMPERIAL GALLON EMERGENCY RINSE TANK

- ▶ 14 imp. gal. (16.8 U.S. gal.)
- ▶ 21" total height
- ▶ Bottom is 10" high, top is 11" high
- ▶ Bottom is 13" wide x 18-<sup>3</sup>/<sub>4</sub>" long
- ▶ Top step is 15" wide x 20-<sup>3</sup>/<sub>4</sub>" long



### 12 IMPERIAL GALLON CONE BOTTOM TANK

- ▶ 12 imp. gal. (14.4 U.S. gal.)
- ▶ 19" diameter
- ▶ 16-<sup>1</sup>/<sub>2</sub>" height
- ▶ 12" lid
- ▶ <sup>3</sup>/<sub>4</sub>" fitting



### 22 IMPERIAL GALLON CONE BOTTOM TANK

- ▶ 22 imp. gal. (26.4 U.S. gal.)
- ▶ 22-<sup>1</sup>/<sub>4</sub>" diameter
- ▶ 21-<sup>1</sup>/<sub>4</sub>" height
- ▶ 12" lid
- ▶ <sup>3</sup>/<sub>4</sub>" fitting



### 83 IMPERIAL GALLON TANK

- ▶ 83 imp. gal. (99.7 U.S. gal.)
- ▶ 30" width
- ▶ 30" height
- ▶ 48" long
- ▶ 8" lid



# ELLIPTICAL SPRAYER TANK

- ▶ Elliptical sprayer tanks are available in translucent white or black. *(Black eliminates algae formation.)*
- ▶ All translucent and black tanks are potable and manufactured from materials that meet FDA Regulations 21 CFR 177.1520 and may be used to contain materials for human consumption.
- ▶ All tanks have greater than UV20 protection to prevent deterioration from sunlight.
- ▶ All tanks come standard with 16" vented lid and a gallonage indicator.
- ▶ 540 and 833 imp. gal. tanks are typically used to contain liquids with densities up to 14 lb per gallon.
- ▶ 1600 imp. gal. tank is heavy duty rated for liquids up to 20 lb per gallon.
- ▶ Elliptical sprayer tanks carry a one 1 Year Warranty against defects in workmanship.



CAPACITY		SPECIFICATIONS					
IMP. GAL.	U.S. GAL.	DIM. A	DIM. B	DIM. C*	LID SIZE	STANDARD FITTING	PART NUMBERS
1600	1920	89"	91"	87"	16"	N/A	1089
833	1000	90"	79"	52"	16"	N/A	1039
540	648	90"	60"	46"	16"	N/A	1154

\*Dimension C does not include the sump.

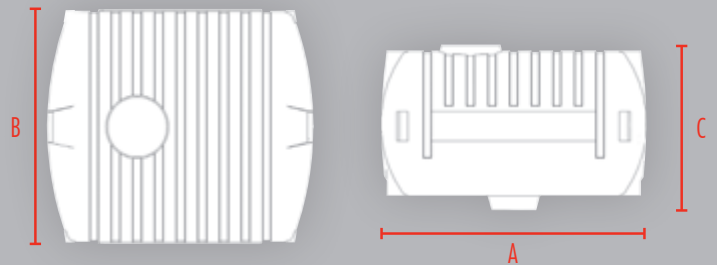

Bourgault models that elliptical tanks will fit. *(Supplied without decals.)*

Convertabar SI	833	Centurion I	833	Exterminator	833	Eliminator 1460	1250
Convertabar SII	833	Centurion II	833	Eliminator 540	540	Eliminator 1850	1600
540 Versabar	833 or 540	Centurion III	833	Eliminator 950	833	LFC2000 Liquid Cart	1600
				Eliminator 1450	1250		

# AUXILIARY SPRAYER TANK

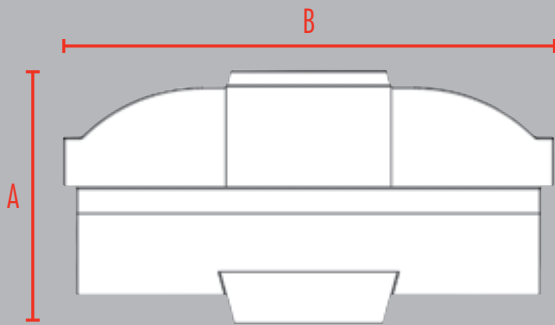

CAPACITY		SPECIFICATIONS					
IMP. GAL.	U.S. GAL.	HEIGHT A	LENGTH B	WIDTH C	LID SIZE	STANDARD FITTING	PART NUMBERS
200	240	45- <sup>3</sup> / <sub>4</sub> "	77- <sup>11</sup> / <sub>16</sub> "	27- <sup>3</sup> / <sub>8</sub> "	16"	2" HD	1179
175	210	43"	63- <sup>1</sup> / <sub>2</sub> "	27- <sup>3</sup> / <sub>8</sub> "	16"	2" HD	1611
125	150	30- <sup>9</sup> / <sub>16</sub> "	63- <sup>1</sup> / <sub>2</sub> "	27- <sup>3</sup> / <sub>8</sub> "	16"	2" HD	1135

- ▶ Auxiliary sprayer tanks are available in translucent white and black.
- ▶ All translucent and black tanks are potable and manufactured from materials that meet FDA Regulations 21 CFR 177.1520 and may be used to contain materials for human consumption.
- ▶ All tanks have greater than UV20 protection to prevent deterioration from sunlight.
- ▶ Tanks come standard with 16" vented lid, bulkhead fitting and built-in sump for more complete drainage.
- ▶ Auxiliary Sprayer Tanks are typically used to contain liquids with densities up to 14 lb per gallon.
- ▶ Auxiliary Sprayer tanks carry a one 1 Year Warranty against defects in workmanship.

# LIQUID FERTILIZER SCALE STATION



- ▶ Heavy-duty design for ground-level or over-head applications.
- ▶ Metal edging around perimeter to allow for easy calibration.
- ▶ Currently available in 1500, 2000, 2500 imperial gallons (1800, 2400 & 3000 U.S. gal.)
- ▶ Cone bottom poly tanks have optimum 10° slope.
- ▶ Can be filled from the top or bottom.
- ▶ Shielded load cells.
- ▶ Anti-Vortex fitting.
- ▶ Full metal bottom.
- ▶ Tank tie-downs.
- ▶ Custom manufacturing available, call Free Form for details.

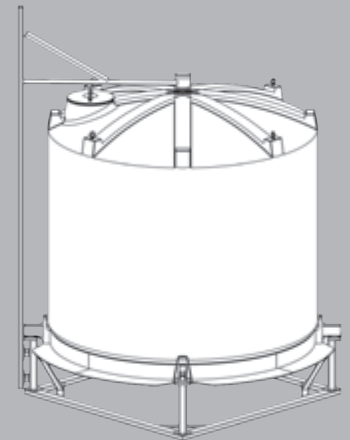

# LIQUID FERTILIZER CART

Free Form liquid fertilizer carts are available in three popular model sizes and come complete with tank, trailer, tires and a ground drive kit. To suit individual needs, customers have the freedom to source their own pumps and plumbing, or to purchase complete kits from Free Form Plastics.



- ▶ The durable cone bottom tank features a 10° minimal slope angle which delivers complete drainage with a low center of gravity for greater stability on uneven terrain. A unique, field-proven gooseneck style hitch allows the tightest of turns.
- ▶ Standard-equipped with a manual disconnect drive.
- ▶ Pump mounting plates installed for most common pumps.
- ▶ Tanks are rated for liquid up to 20 lb per gallon.
- ▶ Tanks are held in place with adjustable nylon straps (*comes with ratchets for ease of adjustment*)

- ▶ Standard equipped with R1 Traction lug tires.
- ▶ Offset wheel tracking reduces soil compaction.
- ▶ Transport light package - standard.
- ▶ Comes standard with an electric drive clutch.
- ▶ Rear tow hitch - standard.
- ▶ Tank access ladder - standard on LC2000 and LC2500 models only.
- ▶ Optional 540/65R24 front and 30.5L x 32R2 Rice lug rear tire package.





The mechanical ground drive system is “quick detach”, has a spring loaded drive chain tensioner and features an adjustment bolt to allow the drive wheel chain and sprocket to remain tight.



The front end of the Free Form LFC is engineered using the proven design of the Bourgault Air Seeder. This design allows for a full range of motion, along with outstanding durability. The large fifth wheel plate resists wear by utilizing a polymer wear pad. The front axle pivots on a lubricated pin and bushing system which offers rugged, trouble-free operation.



The LC series Liquid Cart frame is common throughout the models. This feature allows the user to upgrade the cart’s capacity by simply changing the tank. The frame design has undergone extensive field and endurance testing to ensure years of trouble-free service.

MODEL	CAPACITY		SPECIFICATIONS			
	IMP. GAL.	U.S. GAL.	LENGTH	WIDTH	HEIGHT	STANDARD FITTING
LC-1500	1500	1800	288"	161"	92"	2" HD
LC-2000	2000	2400	288"	161"	108"	2" HD
LC-2500	2500	3000	288"	161"	124"	2" HD

MODEL	STANDARD TIRE		OPTIONAL TIRE	
	FRONT	REAR	FRONT	REAR
LC-1500	21.5L x 16.1 R1 Traction	23.1 x 26 R1 Traction	21.5L x 16.1 R1 Traction	28L x 26 R1 Traction
LC-2000	21.5L x 16.1 R1 Traction	28L x 26 R1 Traction	540/65 R24 R1W Traction	30.5L x 32 R2 Rice Lug
LC-2500	21.5L x 16.1 R1 Traction	28L x 26 R1 Traction	540/65 R24 R1W Traction	30.5L x 32 R2 Rice Lug

*Cart pricing includes tires, excluding 540/65 R24 and 30.5L x 32 R2 Rice Lug*

# PORTABLE LIQUID STORAGE



Free Form designed the PLS to meet increasing demands for on-site liquid storage. The PLS is available in a variety of sizes ranging from 4000 imp. (4800 U.S.) gallons to 7400 imp. (8880 U.S.) gallons. This unit was designed with ease of operation in mind. A self-contained hydraulic system is standard to allow simple conversion from road to field and back. The tanks are heavy-duty 10° cone bottom to allow for complete drainage of product and meet the demanding conditions of our customers. The PLS is suitable for storage of a wide array of liquids including liquid fertilizer, liquid feed supplement, herbicide and water for livestock or spraying operations. Whatever your needs, the PLS meets the increasing demands for on-site liquid storage.



- ▶ An adjustable double clevis hitch is standard on all models. Optional hitch choices include a pintle, or a 2-<sup>5</sup>/<sub>16</sub>" socket. Added safety features include: a double safety chain, a light package, a slow moving sign, and side clearance reflectors. Tires are DOT rated for highway use.
- ▶ Both tanks are conveniently connected to the front of the unit where central loading and unloading can be done. Heavy-duty fittings and valves are used throughout the unit making it very durable. Camlock connections are standard on all hose ends to allow removal of hoses for clean out. (3" plumbing is standard with optional 2" available upon request.)



- ▶ Ball valves are located at the bottom of both tanks to allow complete control of the fluid and to help prevent the possibility of lost product. The valves are operated with ease using remote access handles located on the side of the unit. These handles are lockable to prevent vandalism or theft of the product.



▶ Each tank is secured with three (3) custom-made straps. The straps are bolted to the lifting lugs on the top of the tank with 1/2" bolts and secured to the cone with ratcheting buckles. The ratcheting buckles allow for easy, and necessary adjustment to the strap tension, compensating for changing dimensions caused by temperature variations.

- ▶ Tanks are rated for liquid up to 20 lb per gallon.
- ▶ Tanks have a 10° cone bottom for complete drainage.
- ▶ Adjustable tongue heights with standard double clevis hitch, optional hitches are a pintle or 2-5/16" socket.
- ▶ Minimal trailer tongue weight allows easy towing by a variety of vehicles.
- ▶ Self-contained hydraulic system for fast transporting.
- ▶ Quick & Easy remote valve access.
- ▶ Tires are rated for highway speeds  
(11L x 15" DOT, Goodyear Farm and Highway Service)
- ▶ Complete with standard rear hitch.
- ▶ One "front-fill" connection for ease of loading and unloading with separate valves on each tank.
- ▶ Comes completely plumbed with 3" hose, Banjo valves and cam-lock couplers.
- ▶ Shielded main valve to protect against road damage.
- ▶ Lighting package comes standard.
- ▶ Optional - lockable lids and 2" plumbing.
- ▶ Agitation fittings can easily be installed for mixing of the product.

CAPACITY		SPECIFICATIONS					
IMP. GAL.	U.S. GAL.	WIDTH	HEIGHT	LENGTH	LID SIZE	STANDARD FITTING	SYSTEM WEIGHT (LB)
7400	8880	104"	162"	260"	16" HD	3" HD	4600
5000	6000	104"	122"	260"	16" HD	3" HD	4040
4000	4800	104"	106"	260"	16" HD	3" HD	3600



# SWATH ROLLER

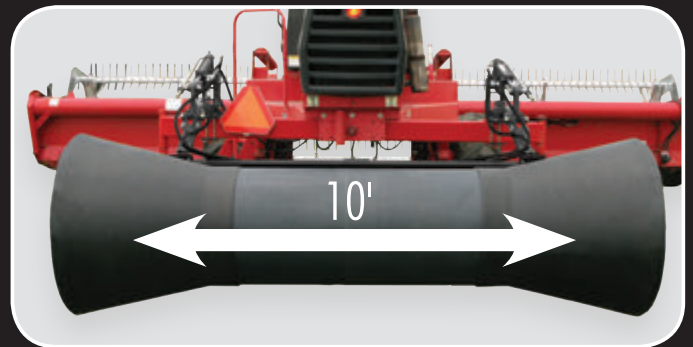

Patented roller is adjustable from 6' to 10' to accommodate multiple crop types and varying crop conditions.

## MOUNTED HYDRAULIC MOUNTED WINCH & TOW BEHIND

Free Form Swath Rollers reduce crop loss by minimizing the effects of wind damage. The patented adjustable width roller enables the operator to easily change the roller width which forces the windrow to be “tucked-in” on the ends maximizing resistance to wind gusts. Another feature (*on mounted models*) is the added weight to the rear of the swather which helps offset the use of larger headers.





Lift and lower your roller in-cab with the press of a button.

# 1 MT2000H MOUNTED HYDRAULIC MODEL



Easy adjust pin-style roller height control and transport locks.

**The Free Form mounted hydraulic swath roller has quickly become the swath roller of choice for producers across North America.**

To fit all swather makes and models, the Free Form hydraulic swath roller takes convenience to the next level with its patented in-cab adjustment allowing you to simply, efficiently and consistently control the roller's position. An additional convenience feature is its high lift capabilities. This feature allows you to continue swathing from canola to wheat without the inconvenience of installing and uninstalling the roller...simply lift the roller and move on to the next field! *(This feature is also extremely beneficial for storage. Lift the roller and keep it on the swather during the off season!)*

The roller's frame is durably constructed of heavy-duty 3" x 2" tubing while the roller itself is constructed of corrosion and dent-proof polyethylene.

# 2 MT2000W MOUNTED WINCH/CABLE MODEL



Adjustment is done manually with a winch/pulley system.

**The Free Form mounted winch/cable swath roller - an economical alternative!**

Like the hydraulic model, the winch cable model is designed to fit all swather makes/models *(hardware is supplied)*. Unlike the hydraulic model, adjustment is done manually by a winch mounted on the rear axle. The MT2000W roller comes standard with the high lift feature for easy transport and storage.

The roller's frame is durably constructed of heavy-duty 3" x 2" tubing while the roller itself is constructed of corrosion and dent-proof polyethylene.

# 3 TB2000 TOW BEHIND MODEL



The quick height adjustment feature on the TB2000 allows the operator to change the height of the roller quickly and easily. The floating roller mode allows the roller to automatically adjust to the different swath sizes. This firms swaths where it is often needed most...where the swaths are the lightest.

# 3-POINT HITCH CULTIVATOR

## Versatile & Tough 3-Point Hitch Cultivator

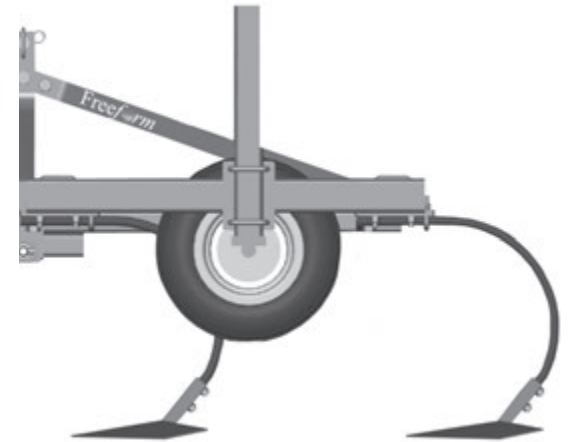

### MODEL 1000 CULTIVATOR

- ▶ 5.25' (7 shanks) standard width, also available in 6.75' (9 shanks) and 8.25' (11 shanks)
- ▶ 9-inch shank spacing with 7/8" shanks.
- ▶ 2-1/2" x 2-1/2" x 3/16" wall frame.
- ▶ 3" x 2" x 3/16" cross members.
- ▶ Optional gauge wheels.
- ▶ Gauge wheel tires — 4.8" x 8", 4 ply.
- ▶ Category I three point hitch.
- ▶ 26-1/2" between shank row beams.
- ▶ Uses 47° sweeps with 1/2" plow-bolts on 1-3/4" centers.
- ▶ Solid shank mount.
- ▶ Can accept sweeps up to 11" wide.
- ▶ Under-frame clearance — 21-1/2".
- ▶ Maximum working depth is 8".
- ▶ Gauge wheels offer good depth control.
- ▶ Rated for tractors up to 65 HP.
- ▶ Approx. unit weights - 5.25' - 360 lb, 6.75' - 465 lb, 8.25' - 565 lb.
- ▶ Weight of gauge wheels — 60 lb.

*3 Year Limited Warranty*

*5 Year Shank Breakage Warranty*



# DOWNSPOUTS & AUGER HOPPERS

## AUGER DOWNSPOUTS

- ▶ Free Form offers two styles of downspouts: regular and bucket.
- ▶ Custom lengths available.
- ▶ Heavy-duty construction for years of trouble-free use.
- ▶ Downspouts carry a one 1 Year Warranty against defects in workmanship.



Regular Downspout



Bucket Downspout

## RETRACTABLE DOWNSPOUTS

- ▶ Adjustable lengths.
- ▶ Heavy-duty construction for years of trouble-free use.
- ▶ Four 4 strap design to prevent spouts from separating when used on angles.
- ▶ Supplied with pulleys and 15' of cable with end loops for quick installation and connection to a winch or operating device.
- ▶ Downspouts carry a one 1 Year Warranty against defects in workmanship.

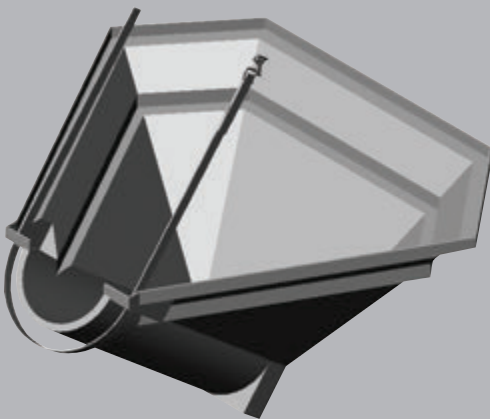

## AUGER HOPPERS

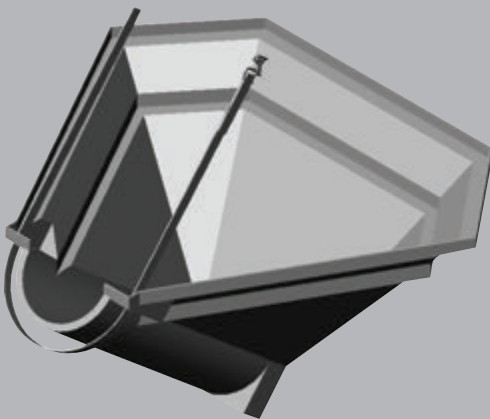

### SPECIFICATIONS

DESCRIPTION	LENGTH	DIA.
14" Auger Downspout - Round	50"	14"
10" Auger Downspout - Round	40"	10"
10" Auger Bucket Spout - Oval	46"	10-1/4"
8" Auger Downspout - Round	38"	9-1/4"
8" Auger Bucket Spout - Oval	46"	8-1/2"
7" Auger Downspout - Round	38"	7-1/4"
7" Auger Bucket Spout - Oval	48"	7"
Downspout Replacement Strap	60"	60"
1" Steel Buckle		
1" Black Plastic Slide		

### SPECIFICATIONS

MODEL	DIMENSION A	DIMENSION B	DIMENSION C
18-1/2" x 11"	18-1/2"	48"	118"

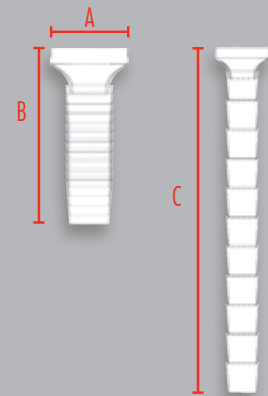

### SPECIFICATIONS

DESCRIPTION	LENGTH	WIDTH	HEIGHT	PART NUMBERS
6" Auger Hopper c/w straps	31-5/16"	34"	19"	2816-6
7" Auger Hopper c/w straps	33-9/16"	36-5/16"	19-1/2"	2816-7
8" Auger Hopper c/w straps	37-1/2"	39-1/2"	20-1/2"	2816-8
10" Auger Hopper c/w straps	49"	41-1/8"	23-1/2"	2816-10

# ROTO-SHEAR



## ROTO-SHEAR

is owned and manufactured by Free Form.

Roto-Shear owners know that when harvesting lodged or tangled crops like canola and peas, this is an essential piece of equipment that they would never be without again. When time matters most, Roto-Shear has proven itself to be dependable in the toughest harvests, cutting through tangled and lodged crops with speed and efficiency.

Each Roto-Shear kit comes complete with divider board, collector rod, mounting brackets and/or braces, hardware and hose kits as required. Roto-Shear's are available to fit almost all applications.





**DIVIDE & SEPARATE  
TANGLED & LODGED  
CROP FROM HEADER**

**ROTO-SHEAR                      REPUTATION                      PRODUCTION**



Roto-Shear is a high quality vertical crop cutter adaptable to all swather and combine header boards. Developed in partnership with local producers, and extensively field tested to bring you the best product possible. Not only does Roto-Shear allow producers to be more profitable, but many happy customers report that it is a joy to use.

The simplicity and quality of the design makes it essentially maintenance-free. Roto-Shear customers declare that it is the most durable and reliable crop cutter they have ever used, outperforming everything else on the market.



# CHEMBINE

## CHEMICAL MIXER

**SAVING TIME & EFFORT!**

**This new product by  
Free Form**

Cutting-edge way of mixing and blending your  
chemicals for your agricultural needs.



75 US Gal / 62.5 Imp Gal / 284 Litres

**Measurements:** 58-<sup>5</sup>/<sub>16</sub>" long x 44-<sup>11</sup>/<sub>16</sub>" wide x 41-<sup>13</sup>/<sub>16</sub>" high

\*based on the base unit





## KNIFE BLOCK

Design provides a more efficiently shaped cut requiring less effort, faster & more complete drainage / rinsing as well as easier removal of the jugs.



## PLUMBING

Available in two sizes:

New 2 inch and 3 inch.

Also comes standard with a 2 inch tote connection, a 1 inch male camlock rinse connection and a garden hose rinse connection.

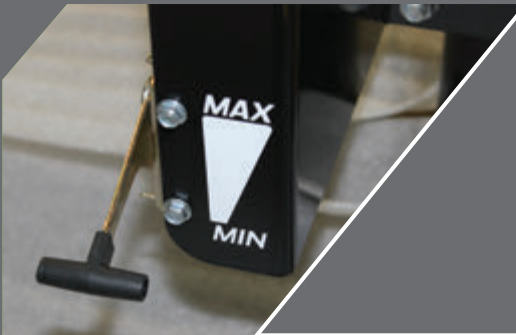

## REMOTE THROTTLE KIT

This kit can be added to either Honda engine

(6.5 or 13 hp) and allows operation of the throttle from the front of the unit.

Allows you to easily vary your throttle as needed to get the best possible performance from your Cheshire with the least amount of effort!



## PUMPS

There are 2 optional pump kits to compliment your Cheshire and create a very functional and compact system.

One is a 6.5 hp Honda with a Wet Seal Banjo pump displacing 256 US gpm (in our actual tests) or a 13 hp electric start Honda with Hypro pump displacing 364 US gpm (in our actual tests). Both kits come on a powder coated frame that bolts to the existing Cheshire, and they have an easy oil drain cut out and additional mounting feet. Both these kits include a 3 way valve that gives you the flexibility to induct or for even quicker fill times pump from the Cheshire tank to fill your sprayer.



## ROTARY RINSE

Easy rinse and drain process with the bottom drain valve, all interior surfaces sloped to the drain and a rotary rinse system with 1 inch lines.

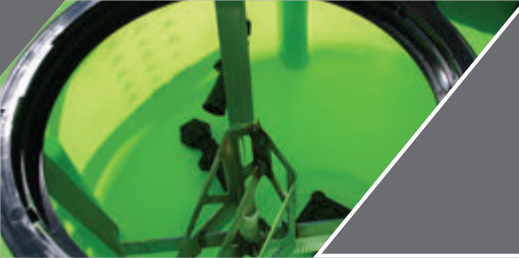

## MIXING

Two agitator jets stir the fluid while the four vertical ribs disrupt the flow increasing the rate of mixing and virtually eliminating the chances of undissolved particles.



## SECURED HINGED TANK LID

Has a raised stop to rest on when open. This raised stop feature molded into the tank reduces reach and effort required to open and close the lid.



## MOUNTING

The frame legs have large feet with pre-drilled holes to allow easy and secure fastening to a trailer or truck deck. The tank is vertically ribbed so that the legs cradle into the tank to give superior agitation plus stability when opening and closing the lid.



## EXPANSION KITS

2 optional kits are available to expand your standard Chembine from the 1 x 2 inch tote connection that it came with:

- 1. Expansion kit** – 2 Tote System expands your Chembine to allow connection of 2 x 1 inch totes and eliminates the 2" tote connection. The kit also includes a Flush Hose Assembly.
- 2. Expansion kit** – 3 Tote System c/w Flow Meter mount expands your Chembine to allow connection of 3 x 1 inch totes in addition to the original 1 x 2 inch tote connection (valve required). This kit can be ordered with or without the Banjo magnetic flow meter in case you want to utilize your existing or another brand. This kit also includes a powder coated stand that connects to the Chembine.

# HOT-TANK

The Hot-Tank allows you to premix your entire chemical load ahead of time. You can reduce your spraying down time by having your entire mixed chemical load ready upon arrival of the empty sprayer. Using the two 3 - way valves, and the existing pump, you are able to control the flow to fill, mix and load from the Hot-Tank. Loading the sprayer can be done by using the existing pump on the Chembine unit.

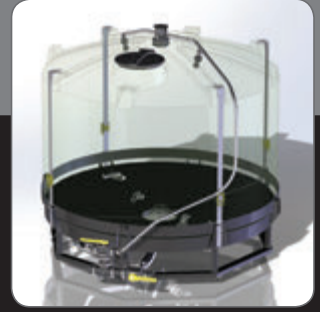

- Easy Clean Out:** 10 degree tapered cone bottom to a 3 inch complete drain bulkhead.
- Simple Operation:** With 2 three way valves to control all functions. Adds maximum speed and efficiency to your operation!
- Agitation:** There are four agitators at the bottom of the tank that agitate and mix the tank.
- Rotary Rinse:** There are two rotary rinse nozzles on the top of the tank that can be used to rinse the tank or mitigate foaming issues.

1680 US Gal / 1400 Imp Gal / 6359 Litres

**Measurements:** 98-<sup>3</sup>/<sub>16</sub>" long x 92-<sup>3</sup>/<sub>16</sub>" wide x 90-<sup>9</sup>/<sub>16</sub>" high



## CHEMBINE DUAL UNIT

Available with a side mount or rear mount setup that includes the 13HP Honda with electric start engine and Hypro pump.

- 2 @:** 75 US Gal / 62.5 Imp Gal / 284 Litres
  - Total Capacity:** 150 US Gal / 125 Imp Gal / 568 Litres
  - Measurements:** 97-<sup>1</sup>/<sub>2</sub>" long x 45" wide x 41-<sup>1</sup>/<sub>2</sub>"
- \*based on the base unit



# easyFlow

## The self-cleaning closed transfer system

Mounts to Cheshire mixer, sprayer, nurse tank, etc.

- Gravity flow means no pumps are required.
- Large diameter for speedy emptying of jugs.
- Ability to empty jug partially and reuse later.
- Built in backflow prevention for safety.
- No spill connection with highest standards of user and environment safety.
- Continuously adjustable flow rates, enabling exact transfer of partial container volumes.
- Rinsing of accessible parts in contact with chemical after partial dosing (adaptors stay connected to the container)
- Fast and complete rinsing of empty containers.
- No more contamination and cleaning of measuring jugs required.
- Jug adaptors fit 63mm containers.





# easyFlow M

## Safe metering and dosing system

- All the benefits of the easyFlow system.
- Mounts next to the sprayer tank, at working height for easy handling on big sprayers.
- Connects to suction line, induction bowl or any other induction system.
- Transfer of entire content or exact metering and dosing of small partial quantities.
- Rinsing of the whole system even after partial emptying of containers.
- Automatic rinsing of the measuring device simultaneously.
- Easy to install as a kit on the Chembine mixer or any sprayer, nurse tank, etc.
- Clear and transparent measuring vessel, inexpensive to replace.



## Closed Transfer Systems

- easyFlow closed transfer systems allow for negligible operator exposure in the transfer of Plant Protection Products to sprayers.
- easyFlow gives no spill connections with the highest standards of user and environmental safety.
- Continuously adjustable flow rates enable exact transfer of Plant Protection Products.
- There is an industry standard neck width of 63mm for all 5 to 15L pesticide canisters, meaning easyFlow adaptors will fit onto all the cans in your shed.
- Rinsing nozzles are incorporated in the container adaptor enabling thorough cleaning of the system and cans.
- The adaptors automatically cut and push back the aluminium seal on a can, so no need to contaminate and fiddle with a knife for seal breaking.



# FENDERCÔ

DELIVERS.

## FENDERCO DELIVERS flexibility.

Constructed of durable Polyethylene plastic, Fenderco fenders deliver flexibility. Where aluminium and steel fenders are rigid in construction and respond to vibrations or impacts by getting bent up or damaged. Fenderco fenders bounce back. Stones and debris are easily deflected down from a Fenderco fender offering maximum protection against flying stones or debris. The Fenderco fender, although flexible in nature, is durability constructed and is built to withstand temperatures of -40 C to +40 C.

## FENDERCO DELIVERS low maintenance.

Since Fenderco fenders are constructed of plastic, and not steel or aluminium, their non-corrosive properties eliminate the need for painting.

The smooth undersurface of the Fenderco fender prevents mud and snow from building up, therefore eliminating the need to clean the fenders; resulting in increased productivity.

## FENDERCO DELIVERS the right fit.

Fenderco fenders are designed to fit graders, backhoes, semi trucks and trailers - single, tandem and tridem axle combinations. Fenderco fenders are impervious to the harsh effects of salt.

**Fenderco fenders are the toughest poly fender on the road; we guarantee it!**

# BACKHOE FENDERS



## DURABLE RUGGED

The Fenderco fender's narrow, but durable profile allows flexibility which enhances debris deflection and maintains structural integrity.



Smooth undersurface helps with the shedding of mud, snow, or other debris resulting in minimized maintenance.

Textured outer surface for scuff resistance.

Where aluminum and steel fenders are rigid in construction and respond to vibrations or impacts by getting bent up or damaged, **Fenderco fenders bounce back.**

**SIMPLE**  
Installation



**FENDERCO  
FENDERS FIT**  
Case, John Deere &  
Volvo Backhoes







# GRADER FENDERS

## DURABLE RUGGED



### Product Listing for Cat Motor Graders

Make/Model	Drive Train		Tire Size				Steering	
	Non-AWD	AWD	1400 X R24	17.5 X R25	1600 X R24	20.5 X R25	Steerable	Non-Steerable
14M	■				■	■		■
140/160M, M2, M3	■	■	*■	*■	■	■	■	■
14H	■				■	■		■
160H/163H/160K	■	■	*■	*■	■	■	■	■
140H/143H/140K	■	■	*■	*■	■	■	■	■

\* Note: Chains can be utilized on the 1400 & 17.5 Rubber, but the brackets for the 1600 & 20.5 Rubber must be used. Please specify when ordering.

Lifetime warranty on fenders against defects.  
1 year warranty on brackets and hardware.



#### Features

- steerable and non-steerable fenders available
- very durable fenders, rear fenders are strong enough to walk on
- 4 quick-release pins allow for easy removal of rear fenders



### Product Listing for John Deere Motor Graders

Make/Model	Drive Train		Tire Size			Steering	
	Non-AWD	AWD	1400 X R24	17.5 X R25	550/65 X R25	Steerable	Non-Steerable
G/GP Series	■	■	■	■	■	■	
C/D Series	■	■	*■	*■			■
B Series	■		*■	*■			■

\* Note: Chains can be utilized on the 1400 & 17.5 Rubber, but the brackets for the 1600 & 20.5 Rubber must be used. Please specify when ordering.

Lifetime warranty on fenders against defects.  
1 year warranty on brackets and hardware.

#### Features

- steerable and non-steerable fenders available
- mud flaps can be flipped up and pinned for easy access to tire
- very durable fenders, rear fenders are strong enough to walk on
- full rear tandem fenders
- 4 quick-release pins allow for easy removal of fender







# GRADER FENDERS

## DURABLE RUGGED



### Product Listing for Volvo Motor Graders

Make/Model	Drive Train		Tire Size				Steering	
	Non-AWD	AWD	1400 X R24	17.5 X R25	1600 X R24	20.5 X R25	Steerable	Non-Steerable
900 Series	■	■	*■	*■	■	■	■	
700 Series 4, 5, 6	■		*■	*■	■	■	■	
700 Series 3	■		*■	*■	■	■	■	

\* Note: Chains can be utilized on the 1400 & 17.5 Rubber, but the brackets for the 1600 & 20.5 Rubber must be used. Please specify when ordering.

#### Features

- steerable and non-steerable fenders available
- very durable fenders, rear fenders are strong enough to walk on
- 4 quick-release pins allow for easy removal of rear fenders



### Product Listing for New Holland Motor Graders

Make/Model	Drive Train		Tire Size				Steering	
	Non-AWD	AWD	1400 X R24	17.5 X R25	1600 X R24	20.5 X R25	Steerable	Non-Steerable
RG 170/200	■	■	*■	*■	■	■		■

\* Note: Chains can be utilized on the 1400 & 17.5 Rubber, but the brackets for the 1600 & 20.5 Rubber must be used. Please specify when ordering.

#### Features

- steerable and non-steerable fenders available
- very durable fenders, rear fenders are strong enough to walk on
- 4 quick-release pins allow for easy removal of rear fenders



# GRADER FENDERS

## DURABLE RUGGED



### Product Listing for CASE Motor Graders

Make/Model	Drive Train		Tire Size				Steering	
	Non-AWD	AWD	1400 X R24	17.5 X R25	1600 X R24	20.5 X R25	Steerable	Non-Steerable
Case 865VHP	■	■	*■	*■	■	■		■
Case 885	■	■	*■	*■	■	■		■

\* Note: Chains can be utilized on the 1400 & 17.5 Rubber, but the brackets for the 1600 & 20.5 Rubber must be used. Please specify when ordering.

#### Features

- steerable and non-steerable fenders available
- very durable fenders, rear fenders are strong enough to walk on
- 4 quick-release pins allow for easy removal of rear fenders



### Product Listing for Komatsu Motor Graders

Make/Model	Drive Train		Tire Size				Steering	
	Non-AWD	AWD	1400 X R24	17.5 X R25	1600 X R24	20.5 X R25	Steerable	Non-Steerable
GD 655-3	■	■	*■	*■	■	■		■
GD 655-5/6	■	■	*■	*■	■	■		■

\* Note: Chains can be utilized on the 1400 & 17.5 Rubber, but the brackets for the 1600 & 20.5 Rubber must be used. Please specify when ordering.

#### Features

- steerable and non-steerable fenders available
- very durable fenders, rear fenders are strong enough to walk on
- 4 quick-release pins allow for easy removal of rear fenders



# TRUCK & TRAILER FENDERS

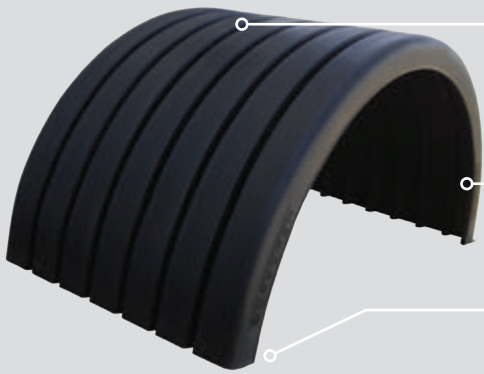

Textured outer surface for scuff resistance.

Smooth undersurface helps with the shedding of mud, snow, or other debris resulting in minimized maintenance.

The Fenderco fender's narrow, but durable profile allows for flexibility which enhances debris deflection and maintains structural integrity.

Fenderco fenders are backed by a lifetime warranty.\*

Assuming proper installation and conventional usage, Fenderco guarantees their poly fenders for life to the original owner.

\*refer to the Fenderco Lifetime Warranty policy for specific details.

Fit most semi-truck & semi-trailer applications.  
Mounting hardware not included.

## TRUCK & TRAILER FENDERS

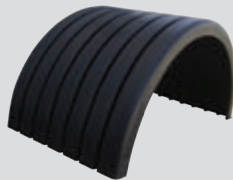

**RTR-180**  
Round Full Fender  
Use M-RTF-180 mounting kit

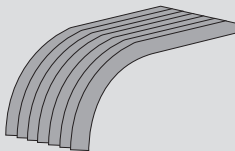

**RTF-60**  
Round Half Fender  
Use M-RTF-60 mounting kit

**STF-60** Standard Half Fender  
Use M-RTF-60 mounting kit

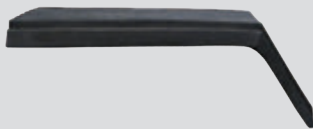

**STF-3** Standard Full Fender  
Use M-RTF-180 mounting kit



## TANDEM TRAILER FENDERS

**TTF-72** Single Tandem Trailer Fender  
Mounting kit not available



**M-RTR-180**  
Universal straight bolt-on fender mount kit



**M-RTF-60**  
Universal offset style bolt-on fender mount kit



## MOUNTING KITS



# TANKGUARD

# 90



## WIRELESS MONITORING SOLUTIONS FOR HIGHLY CORROSIVE CHEMICALS

- Ceramic differential pressure sensor solution, with TankGuard 90.
- Stands up to challenges associated with monitoring highly corrosive chemicals.
- Easier to install and eliminates false reading and bouncing associated with ultrasonic sensors.
- Innovative, ultra-low profile monitor enclosure and internal antenna for corrosive chemical compatibility and ruggedness. Monitor can be removed and re-deployed
- Leverages technology that operates on 3G/4G networks, for longevity

**The TankGuard 90 ceramic DP sensor monitoring solution redefines what's possible when monitoring highly corrosive chemicals. How? By delivering a differential pressure sensor in a heretofore ultrasonic world. We couple our innovative form factor TankGuard 90 monitor with a ceramic DP sensor that will stand up to the harshest chemicals. The result? Easier installation and higher accuracy level readings, by placing the sensor at the bottom of the tank and avoiding vapours on top that can cloud the measurement.**

### Lowest Profile in the Industry

The unique, low profile domed design of the TankGuard 90 minimizes the height of the exposed part of the device to less than 2 1/2" above the vessel. The electronics are housed safely in the portion of the device recessed within the tank, and the antennae are under the domed cover. So, whether your tank/totes are stacked or not, the hardware is out of harms way.

### Integrated GPS for Asset Tracking

Knowing exactly where your tank and totes are is often just as important as knowing level, temperature and other tank information. The TankGuard 90 features integrated GPS functionality as well as Map Pin capability, enabling you and the driver to know where the tank is, whether you're on the lot or miles away, and whether the tank is outside or inside a building. Location information is at your fingertips, through Tank locator and TankData Online.

### Data When & Where You Need it

To meet the challenges of supplying or replenishing chemicals, you need to know:

- Current inventory position of the tank(s) in use
- How many other tanks are at the customer location
- How many are full and how many are empty
- Exactly where they are

The TankGuard 90 and TankData Online give you the information you need to maximize supply chain efficiencies and customer service while minimizing costs.



## BOLDLY GOES WHERE NO DIFFERENTIAL PRESSURE SENSOR HAS GONE BEFORE

Corrosive chemicals and acids like HCl and H<sub>2</sub>SO<sub>4</sub> can wreak havoc on the average stainless steel DP sensor, causing operators to rely on harder to install ultrasonic sensors that can produce false readings due to bouncing off vapours instead of liquids. That all changes with the TankGuard ceramic DP sensor monitoring solution. Now, with a ceramic housing protecting the sensor from corrosion, you can use reliable, accurate DP sensor at the bottom of the tank and avoid the vapour effect that ultrasonic sensing can produce.

Our single-source solution of hardware, sensor and data delivery service provides secure, key tank information 24/7. In the office or the field, you'll know the tank location, level and when replenishment is needed.

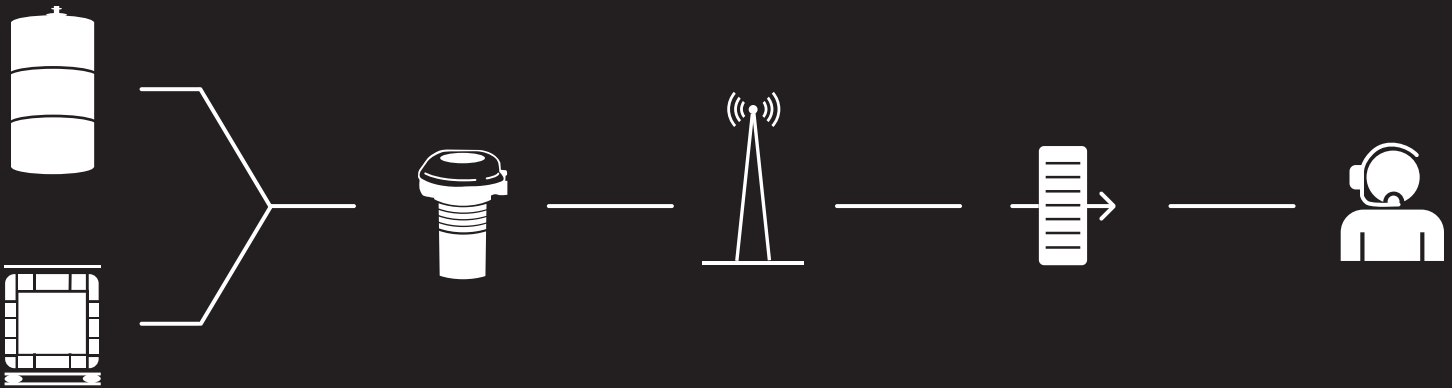

### TankGuard 90 Specifications

**Construction:** ROHS Compliant

Enclosure: NEMA 4X, weatherproof, UL approves (UL94V-0), CPVC

**Process Fitting:** Simultaneous 2" NPT and 2" Buttress

**Unit Gross Weight:** 1.3 lbs (454g)

**Operating Environment** (monitor) Storage

Temperature Range: -40°F to 185°F (-40°C to 85°C)

**Operating Temperature Range:** (Electronics)

-22°F to 158°F

(-30°C to 70°C)

### Cellular Communications

**Mode:** GSM Digital Wireless Radio

**RF APPROVAL** FCC 850/1900 MHz

**GPS Receiver:** Internal Antenna

Optional External GSM Antenna

### Performance Specifications

**Output Voltage:** Nominally 14V/24V

**Output Current:** Rated from

0 - 50 mA

**Load Regulations:** 0.5% from

@30 mA load

**Ripple:** 50 mV Peak-to-Peak

**Output Short Circuit Protection:** Current limited

to 50 mA

**Accuracy:** +/-0.25%, +/-0.50%,

+/-1.0% Based on require



# TANKGUARD

## PROPHET 4000 SERIES

### WIRELESS REMOTE TANK MONITORING SOLUTION



- Reports level, location, temperature, usage history and demand forecast information 24/7 via TankData online, TankGuard's web portal.
- Sensor inflexibly interfaces with contacting or non-contacting sensor to monitor virtually any stored liquid or solid.
- No end user facilities required - data is transmitted by the 3G GSM/CDMA cellular networks.
- No external power source required - unit is powered by internal replaceable lithium-ion batteries with an anticipated life of up to 6000 callouts.
- WLAN support for up to ten (10) Prophet Clients.
- Simple installation and quick commissioning.

The Prophet 4000 Series telemetry monitor provides a cost effective, single-source remote inventory monitoring and reporting solution for bulk, mini-bulk and IBC tanks and totes. Engineered into a sleek, compact and weather proof enclosure, the Prophet can be supplied with either contacting (differential pressure) or non-contacting (ultrasonic) sensors when no other existing instrumentation is available.

#### Simple and Quick

The prophet is typically installed within 15 minutes by non-technical personnel. Once activated, final provisioning can be completed by the customer or through a quick call to TankGuard Customer Service, and your inventory data is available 24/7 via TankData Online, TankGuard's portal.

The unit can also be quickly redeployed if needed on any other tank.

#### Integrated GPS for Asset Tracking Fixed Monitoring Costs

Affordable monthly subscription service to TankData Online includes 24/7 internet-based access to tank data, plus all cellular long distance and roaming. Unlike other service vendors, you won't see any hidden charges or overage fees from TankGuard. Once your monthly service fee is quoted, that's the amount you will be billed.

#### TankGuard Cellular Monitoring

- Access tank data 24/7 via PC, laptop, smartphone or tablet.
- Export delivery/routing data to Excel or your routing package.
- Track delivery efficiency and calculate potential savings.
- Pro-actively service your customers.
- **MODE:** 3G GSM/CDMA Digital Wireless Radio
- **FREQUENCY BANDS:** GSM/CDMA 850/1900MHz

**The Prophet 4000 Series, combined with TankData Online can help eliminate runouts and costly emergency deliveries, and increase operations efficiency up and down the supply chain.**

Using a standard internet browser, you can retrieve and use valuable tank information virtually anywhere in the world, whether the tank is local or a thousand miles away. You'll make smart, data-driven replenishment decisions, delivering more product left often, with fewer expensive truck rolls.

It's completely wireless and suited for stationary or mobile tanks, and delivers data using digital cellular technology. Designed for daily callouts, both scheduled and event-driven, the Prophet delivers inventory level, precise tank location, battery status, signal strength usage history and demand forecasting information, as well as alarms and notifications.

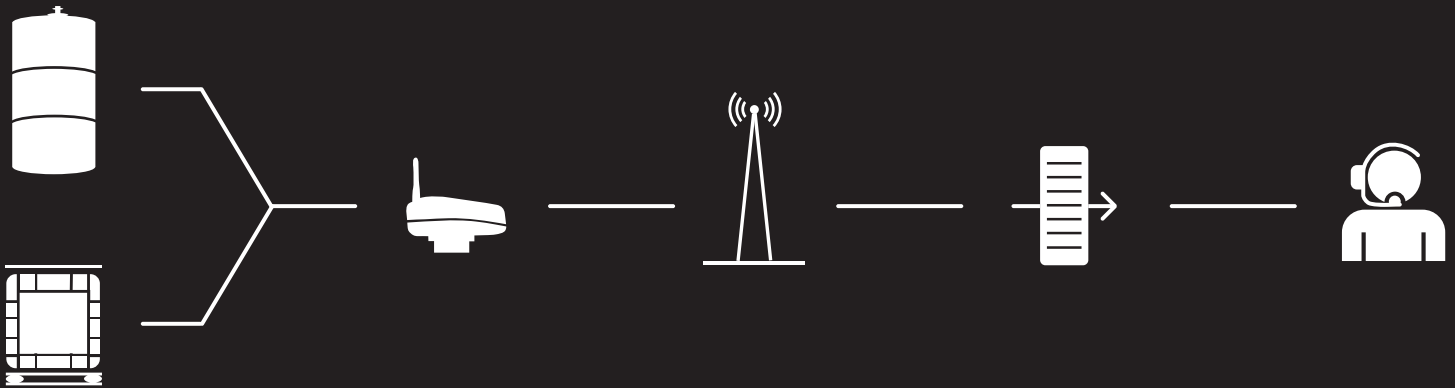

### Performance Specifications

**Output Voltage:** Nominally 14V - 24V (based on Model #)

**Output Current:** Rated from 0 - 50 mA

**Load Regulation:** 0.5% @ 30 mA load

**Ripple:** 50 mV Peak - Peak

**Output Short Circuit Protection:** Output current limited to 50 mA

**Accuracy:** +/-0.5% of Span

### Hardware Specifications

**Enclosure:** NEMA 4X: weather-proof: UL approved (UL94HB); glass-filled nylon

**Process Fitting:** 2" Polypropylene NPT (5.08cm)

**Area Classification:** Ordinary location

**Unit Gross Weight:** 2.1 lbs (0.95kg)

### Battery & Environment

**Type:** Two replacement 3V lithium batteries (Panasonic CR-123A, manganese dioxide)

**Supply Voltage:** 6V

**Expected Life:** Up to 6000 updates (4200 mA Hours) (Depending on final configuration)

**Storage Temperature Range:** -40°F to 185°F (-40°C to 85°C)

**Operating Temperature Range:** (Electronics) -22°F to 158°F (-30°C to 70°C)

# POLAR GRIP...

*leaves a good impression.*



**POLAR  
GRIP**  
TRUCK WEIGHT SYSTEM



The Polar Grip Truck Weight System includes planks featuring an embossed gripping system that provides excellent footing when walking in the box. It can be purchased to cover the entire floor of the truck bed, or if less weight is needed, half of a system can be installed.



#### INCREASED SAFETY

The Polar Grip truck weight system steadies your ride giving you better traction on icy or snowy roads giving you a smoother ride year round.



#### FAST AND EASY INSTALL

The Polar Grip truck weight system easily installs in a matter of minutes.

1. Fill each plank with sand through pre-drilled holes.
2. Align planks. Using supplied hardware bolt planks together.
3. Can be bolted or tethered to your vehicle for a secure fit.



#### ADD WEIGHT, WHILE MAINTAINING CARGO SPACE

Although the Polar Grip truck weight adds up to approximately 600 lb of weight to a full size truck bed, it takes up little space occupying a mere 2-3/8" from the bottom of your truck bed.





# POLYTOON™





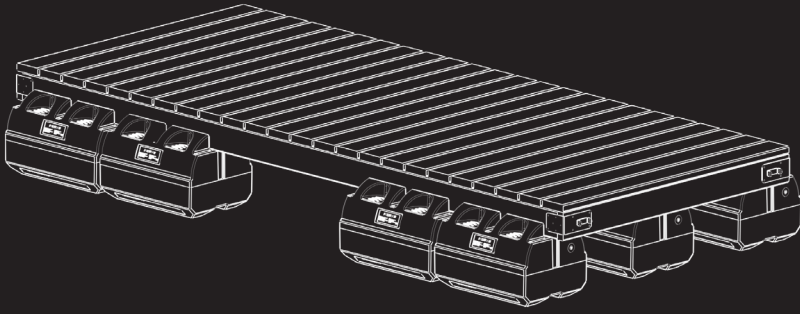

The Polytoon System allows customers to create a dock or platform of any shape and size. The decking is generally made from outdoor wood because the Polytoon systems receiving slots are sized for regular dimensional lumber.

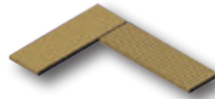

You can do all of the wood construction yourself or have Free Form Plastics construct a completed platform to your specifications. Delivery to your location can also be arranged.

Free Form also offers a full line of the highest quality, most durable hinges and braces available anywhere in the marketplace. One simply cannot claim to have a great dock system without high quality attaching hardware. These hinges and braces are electrochemically plated to ensure excellent resistance against corrosion.



1138



1110



1136



1137

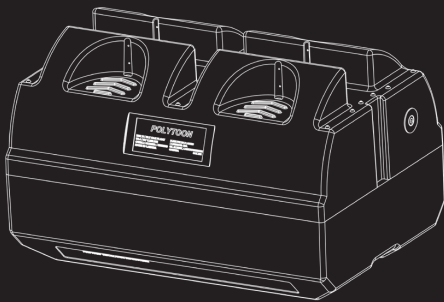

1046

*Wheeled Polytoons are also available.  
Making moving your docks much easier!*

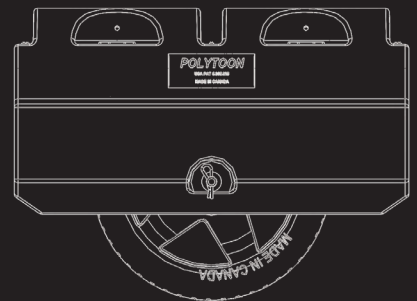

26000-30

The Polytoon floats are made from high density polyethylene. They are rugged and will not get brittle in cold temperatures. The Polytoons are not only easy to install and low maintenance, they have been designed to incorporate a number of innovative features to ensure endless hours of enjoyment.

The Polytoon System is also very flexible and allows the customer to apply Polytoons to a multitude of applications, limited only by one's imagination.



**POLYTOON™ DOCK SYSTEM**

# Freeform WARRANTY



## FREE FORM PLASTIC PRODUCTS - TANKS

All Free Form Plastic Products tanks are warranted on a Pro-Rated basis against defects in materials and workmanship for a period of one hundred and twenty (120) months (10 Years) from the date of delivery to the first retail purchaser.

PRO-RATED WARRANTY will provide 100% coverage in year one (1). The first retail purchaser will contact the nearest dealer who will start a claim with Free Form Plastic Products. Free Form reserves the right to repair or replace the defective tank at its discretion. After year one (1) the value of the tank covered by the warranty will decrease by 10% of the original purchase price. This will continue on through year 10 till the amount covered is zero (0). In no event shall the owner be entitled to recover for incidental, special or consequential damages such as, but not limited to: loss of profit or revenue, product or clean up or any other commercial losses, inconvenience or cost of rental of replacement equipment or the like.



## FREE FORM PLASTIC PRODUCTS, CHEMBINE, FENDERCO, ROTOSHEAR, POLAR GRIP, POLYTOON ALL OTHER FREE FORM PLASTIC PRODUCTS

manufactured items along with the Chembine, Fenderco, RotoShear, Polar Grip and Polytoon products are warranted for a period of twelve (12) months (1 year) from delivery to the first retail purchaser. In the event of a defect being found in this time-frame Free Form Plastic Products will repair or replace, at its option without charge for parts or labour. Some of these products will have extended warranties that will apply and any purchased components or items not directly manufactured by Free Form Plastic Products will carry a separate warranty directly from that manufacturer. \*Note: for specific warranties relating to a specific product or brand contact Free Form or refer to your supplied manual. In no event shall the owner be entitled to recover for incidental, special or consequential damages such as, but not limited to: loss of profit or revenue, product or clean up or any other commercial losses, inconvenience or cost of rental of replacement equipment or the like.



## FENDERCO FENDERS

Fenderco plastic fenders are covered by a Lifetime Warranty against manufacturer defects and workmanship to the original retail purchaser. This warranty does not cover abuse, damage which is the result of improper installation or damage from tires or trailers. In no event shall the owner be entitled to recover for incidental, special or consequential damages such as, but not limited to: loss of profit or revenue, product or clean up or any other commercial losses, inconvenience or cost of rental of replacement equipment or the like.

\*All warranties require the product to be returned to the manufacturer at the purchasers' expense for evaluation and determination of warranty.



# METRIC CONVERSION TABLE

## AREA

Acre (ac) x 0.4047 =	Hectare (ha)
Acre (ac) x 43560 =	Square Feet (ft <sup>2</sup> )
Hectare (ha) x 2.471 =	Acre (ac)
Hectare (ha) x 10000 =	Square Meter (m <sup>2</sup> )
160 Acres (ac) =	64.75 Hectares (ha)

## LENGTH

Inch (in) x 2.54 =	Centimetre (cm)
Feet (ft) x 0.3048 =	Meter (m)
Mile (mi) x 1.6093 =	Kilometre (km)
Mile (mi) x 5280 =	Feet (ft)
Centimetre (cm) x 0.3937 =	Inches (in)
Meter (m) x 3.2808 =	Feet (ft)
Kilometre (km) x 0.6215 =	Mile (mi)
Kilometre (km) x 1000 =	Meter (m)

## WEIGHT

Pounds (lb) x 0.0005 =	Ton
Pound (lb) x 0.4536 =	Kilogram (kg)
Ton x 0.9072 =	Tonne
Ton x 2000 =	Pounds (lb)
Kilogram (kg) x 2.2046 =	Pound (lb)
Kilograms (kg) x 0.001 =	Tonne
Tonne x 1.1023 =	Ton
Tonne x 1000 =	Kilograms (kg)

## RATES

Pounds/Acre (lb/ac) x 1.1227 =	Kilogram/Hectare (kg/ha)
Kilogram/Hectare (kg/ha) x 0.8922 =	Pounds/Acre (lb/ac)
Kilograms/Acre (kg/ac) x 2.2046 =	Pounds/Acre (lb/ac)
Pounds/Acre (lb/ac) x 0.4536 =	Kilograms/Acre (kg/ac)
IMP Gallons/Acre (gal/ac) x 11.232 =	Litres/Hectare (l/ha)
US Gallons/Acre (gal/ac) x 9.353 =	Litres/Hectare (l/ha)
Litres/Hectare (l/ha) x 0.089 =	IMP Gallon/Acre (gal/ac)
Litres/Hectare (l/ha) x 0.1067 =	US Gallons/Acre (gal/ac)

## SPEED

Miles per Hour (mph) x 1.6093 =	Kilometers per Hour (km/h)
Kilometers per Hour (km/h) x 0.6214 =	Miles per Hour (mph)

## VOLUME

Cubic Feet (ft <sup>3</sup> ) x 0.8039 =	Bushel (bu)
Cubic Feet (ft <sup>3</sup> ) x 0.0283 =	Cubic Meter (m <sup>3</sup> )
Cubic Yard (yd <sup>3</sup> ) x 0.7646 =	Cubic Meter (m <sup>3</sup> )
Bushel (bu) x 1.2439 =	Cubic Feet (ft <sup>3</sup> )
Bushel (bu) x 0.0352 =	Cubic Meter (m <sup>3</sup> )
Bushel (bu) x 35.2391 =	Litres (l)
Cubic Meter (m <sup>3</sup> ) x 35.3147 =	Cubic Feet (ft <sup>3</sup> )
Cubic Meter (m <sup>3</sup> ) x 1.3095 =	Cubic Yard (yd <sup>3</sup> )
Cubic Meter (m <sup>3</sup> ) x 28.4071 =	Bushel (bu)
Cubic Meter (m <sup>3</sup> ) x 1000 =	Litres (l)
Litres (l) x 0.0284 =	Bushel (bu)
Litres (l) x 0.22 =	IMP Gallon (gal)
Litres (l) x 0.001 =	Cubic Meter (m <sup>3</sup> )
Litres (l) x 0.2642 =	US Gallon (gal)
IMP Gallon (gal) x 1.201 =	US Gallons (gal)
IMP Gallon (gal) x 4.5461 =	Litres (l)
IMP Gallon (gal) x 160 =	IMP Ounces (oz)
US Gallons (gal) x 0.8327 =	IMP Gallon (gal)
US Gallons (gal) x 128 =	US Ounces (oz)
US Gallon (gal) x 3.7854 =	Litres (l)

## DENSITY

Pounds/Cubic Foot (lb/ft <sup>3</sup> ) x 16.0282 =	Kilograms/Cubic Meter
Kilograms/Cubic Meter (kg/m <sup>3</sup> ) x 0.0624 =	Pounds/Cubic Foot

## PRESSURE

Pounds/Square Inch (lb/in <sup>2</sup> ) x 6.8948 =	Kilopascal (kpa)
Kilopascal (kpa) x 0.145 =	Pounds/Square Inch (lb/in <sup>2</sup> )

## TEMPERATURE

(Degrees Fahrenheit (°F) - 32) x .556 =	Degrees Celsius (°C)
(Degrees Celsius (°C) x 1.8) + 32 =	Degrees Fahrenheit (°F)



**FREE FORM PLASTICS**

Box 159 St. Brieux, Saskatchewan, S0K 3V0 Canada

**P:** 306.275.2155

**F:** 306.275.2101

**E:** [sales@freeformplastics.com](mailto:sales@freeformplastics.com)

 [freeformplastics.com](http://freeformplastics.com)

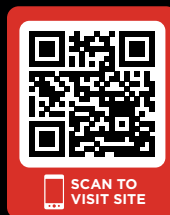

**Follow us**



PRINTED IN CANADA